



# Universal 1 Series

ROTARY POSITIVE DISPLACEMENT PUMPS



**> Waukesha Cherry-Burrell®**

For more than half a century, Waukesha Cherry-Burrell has been a leader in the design, manufacturing and application of external circumferential piston (ECP) style, rotary positive displacement pumps. Waukesha Cherry-Burrell PD pumps are in service around the world in food, dairy, canning, bakery, beverage and pharmaceutical processing, as well as difficult chemical and industrial applications.

Users of Waukesha Cherry-Burrell PD pumps benefit from decades of continuing product improvement. Steady advances in design, metallurgy and fabrication techniques have yielded progressively higher levels of performance and service life.

## Setting the standard of performance for the sanitary industry for over 50 years.

### PRODUCT FEATURES AND BENEFITS

#### Sanitation features

- 316L stainless steel body, cover, and shaft
- Easy disassembly for COP cleaning
- Elastomers that comply with FDA requirements
- Aseptic models available
- Meets 3A sanitary standards

#### Long-life features

- Up to 200 (13.8 bar) psi pressure capability\*
- No bearings in product zone
- Heavy duty bearing frame with large diameter shafts
- Grease lubed bearings for positive lubrication of all bearing over entire speed, temperature and pressure range
- Exclusive, non-galling Waukesha "88" alloy rotors standard; permits running at tighter clearances and pumping a wide range of viscosities
- Remanufacturing and Inspect and Advise programs to extend life and reduce costs

#### Available options

\*High strength 17-4 PH shafts and hex cover nuts for higher pressure applications

- Stainless steel gear case
- Stainless steel bearing retainers
- Bearing isolators protect bearings from contamination
- Body retaining screws
- Steel-It paint
- Single wing rotors for minimum damage of particulates.
- Jacketed or vented covers
- Rectangular flange inlet for high viscosity products
- Tru-Fit™ close coupled pump design

## Installation Features

- Bidirectional flow. Rotors, locked with double jam nuts, rotate securely in either direction.
- No flow direction/shaft position specifications
- Versatile 3-Way mounting of gear case, including vertical alignment of ports
- Upper or lower shaft position
- Easy to install or convert single O-ring to mechanical seals
- Interchangeable installation dimensions with Universal II and Universal Lobe PD pumps



Shown with optional stainless steel gearcase



## Typical product applications

### Bakery

Batters  
Flavorings  
Frostings  
Fruit Fillings  
Fats & Oils  
Sweeteners  
Yeast Slurry



### Beverage

Beer, Wort, Yeast  
Soft Drinks  
Juice  
Fruit Concentrates  
Fruit Drinks  
Wine  
High Fructose Corn Syrups (HFCS)



### Canning

Baby Foods, Soups, Stews  
Tomato Paste/Sauces  
Fruit Puree  
Vegetables, Diced, Slurries  
Puddings, Jams, Jellies  
Salad Dressings, Mayonnaise



### Confectionery

Syrups  
Cream Fillings  
Chocolate



### Cosmetics

Face Creams & Lotions  
Hair Styling Gels & Liquids  
Essential Oils  
Dyes & Alcohols  
Shampoos

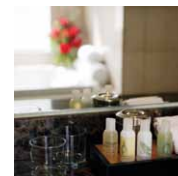

### Dairy

Cream, Milk, Butter  
Cheese Curd & Whey  
Cottage Cheese  
Yogurt



### Meat Packing

Meat-Emulsions  
Ground Meats  
Pet Foods  
Ruffle & Caul Fat  
Mechanically Deboned Meat (MDM)



### Pharmaceutical/Health Care

Pill Pastes  
Syrups  
Extracts  
Emulsions  
Slurries  
Tooth Paste



## Time-tested Waukesha Cherry-Burrell rotary pump; external circumferential piston (ECP) operating principle.

### THEORY OF OPERATION

In the Waukesha Cherry-Burrell design, arc-shaped “pistons” (rotor wings) travel in annular-shaped cylinders machined in the pump body; the resulting long sealing path reduces slippage and produces a smooth flow of product without destructive pulses or pressure peaks and without valves or complex parts.

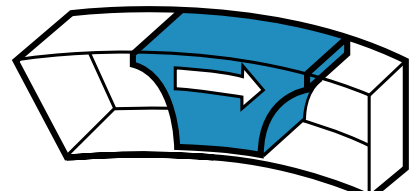

### FOR LOW VISCOSITY FLUIDS

Rotors, made of exclusive Waukesha “88” alloy, can be run with close clearance to the 316L stainless steel fluid head, without galling or seizing should inadvertent pressure surges cause contact. The close clearances combined with the rotor geometry, which gives a long sealing path between the pump inlet and outlet, means low slip operation. As a result, you achieve: high volumetric efficiency, good priming ability, metering capability and good flow control.

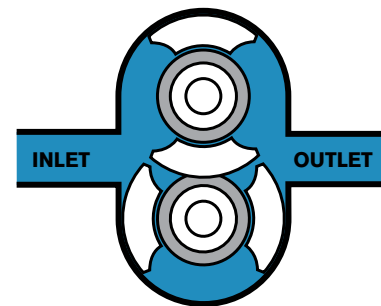

### FOR HIGH VISCOSITY FLUIDS

The large fluid cavities of the rotors, plus the large easy entry anti-cavitation ports, allow efficient pumping of high viscosity fluids, slurries or even liquids with large chunks or particles.

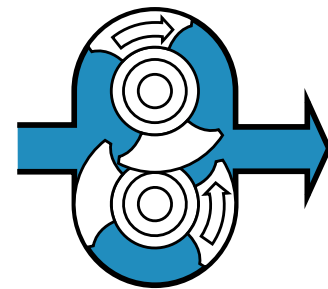

### FOR NON-LUBRICATING AND ABRASIVE FLUIDS

The unique Waukesha Cherry-Burrell design has no bearings in the fluid being pumped, no sliding or rolling contact and no rotor-to-rotor contact. This produces MAXIMUM SERVICE LIFE even under severe operating conditions.

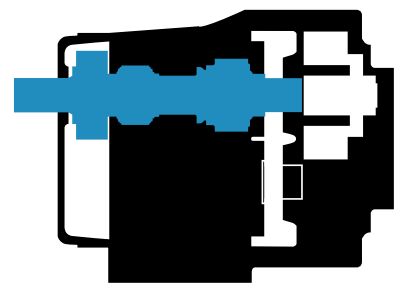

## PRODUCT SPECIFICATIONS

### UNIVERSAL I MODELS

MODEL	DISPLACEMENT PER REVOLUTION	NOMINAL CAPACITY* TO	INLET/OUTLET	OPTIONAL INLET/OUTLET	PRESSURE RANGE UP TO**	MAXIMUM RPM	TEMP RANGE**
006-U1	.0082 GAL. (.031 Liter)	6 GPM (1.3 m <sup>3</sup> /hr.)	1"	1 1/2"	200 PSI (13.8 bar)	800	(-)40 °F /(-)40 °C to 300 °F (149 °C)
015-u1	.0142 gal. (.054 liter)	9 GPM (2.0 m <sup>3</sup> /hr.)	1 1/2"	--	200 PSI (13.8 bar)	700	
018-u1	.029 gal. (.110 liter)	17 GPM (3.8 m <sup>3</sup> /hr.)	1 1/2"	2"	200 PSI (13.8 bar)	600	
030-u1	.060 gal. (.227 liter)	36 GPM (8.2 m <sup>3</sup> /hr.)	1 1/2"	2"	200 PSI (13.8 bar)	600	
040-u1	.076 gal. (.288 liter)	45 GPM (10.2 m <sup>3</sup> /hr.)	2"	2 1/2"	150 PSI (10.3 bar)	600	
060-u1	.153 gal. (.579 liter)	90 GPM (20.4 m <sup>3</sup> /hr.)	2 1/2"	3"	200 PSI (13.8 bar)	600	
130-u1	.254 gal. (.961 liter)	150 GPM (34.1 m <sup>3</sup> /hr.)	3"	--	200 PSI (13.8 bar)	600	
220-u1	.522 gal. (1.976 liter)	310 GPM (70.4 m <sup>3</sup> /hr.)	4"	--	200 PSI (13.8 bar)	600	
320-u1	.754 gal. (2.854 liter)	450 GPM 102 m <sup>3</sup> /hr.)	6"	--	200 PSI (13.8 bar)	600	

### RECTANGULAR FLANGE MODELS

MODEL	DISPLACEMENT PER REVOLUTION	NOMINAL CAPACITY* TO	INLET W X L INCHES	OUTLET	PRESSURE RANGE UP TO**	MAXIMUM RPM	TEMP RANGE**
014-U1	.0142 GAL. (.054 LITER)	5 GPM (1.1 m <sup>3</sup> /hr.)	1.5 X 4.75	1 1/2"	200 PSI (13.8 bar)	400	(-)40 °F /(-)40 °C to 300 °F (149 °C)
024-U1	.029 GAL. (.110 LITER)	11 gpm (2.5 m <sup>3</sup> /hr.)	1.31 X 4.93	1 1/2" (2")	200 PSI (13.8 bar)	400	
034-u1	.060 GAL. (.227 LITER)	24 gpm (5.4 m <sup>3</sup> /hr.)	1.75 X 6.75	2"	200 PSI (13.8 bar)	400	
064-U1	.153 GAL. (.579 LITER)	60 gpm (13.6 m <sup>3</sup> /hr.)	2.24 x 8.82	2 1/2" (3")	200 PSI (13.8 bar)	400	
134-U1	.254 GAL. (.961 LITER)	100 gpm (22.7 m <sup>3</sup> /hr.)	2.97 x 9.25	3"	150 psi (10.3 bar)	400	
224-U1	.522 GAL. (1.976 LITER)	200 gpm (45.4 m <sup>3</sup> /hr.)	3.87 x 11	4"	200 PSI (13.8 bar)	400	
324-U1	.754 GAL. (2.854 LITER)	300 gpm (68.1 m <sup>3</sup> /hr.)	5 x 17.38	6"	200 PSI (13.8 bar)	400	

### ASEPTIC MODELS

MODEL	DISPLACEMENT PER REVOLUTION	NOMINAL CAPACITY* TO	INLET/OUTLET	PRESSURE RANGE UP TO**	MAXIMUM RPM	TEMP RANGE**
033A	.051 GAL. (.193 LITER)	30 GPM (6.8 m <sup>3</sup> /hr.)	1 1/2"	225 PSI (15.5 bar)	600	(-)40 °F (-)40 °C to 300 °F (149 °C)
133A	.205 GAL. (.776 LITER)	120 gpm (27.3 m <sup>3</sup> /hr.)	3"	225 PSI (15.5 bar)	600	
223A	.440 GAL. (1.666 LITER)	260 gpm (59.1 m <sup>3</sup> /hr.)	4"	225 PSI (15.5 bar)	600	
323A	.616 GAL. (2.332 LITER)	360 gpm (81.8 m <sup>3</sup> /hr.)	6"	225 PSI (15.5 bar)	600	

\*For capacities above 450 to 935 GPM, see bulletin FH-1725 on 420/520 UHC (ECP Rotors) and FH-1733 on 420/520 UHCL (Lobe Rotors).

\*\*Contact application engineering for higher pressure or higher temperature applications.

Note: Universal II (Bulletin FH-1723) and Universal Lobe (Bulletin FH-1733) models are available for CIP installations, applications up to 500 psi, and extended run services not needing frequent tear down for cleaning.

# Time-Tested Waukesha Cherry-Burrell Rotary Pump.

## The Waukesha Cherry-Burrell Universal I Series gives you...

**High pressure capability;** up to 200 psi/13.8 bar\*.

**Long service life:** High capacity components for long trouble-free service.

**The right seal** for every application, plus easy interchangeability when needed.

**Metal rotor:** Waukesha "88" non-galling alloy, for close running clearance.

**Design conforms,** to 3A, USDA, ISO 9001:2000 and CE standards.

\*For higher pressures, consult the factory.

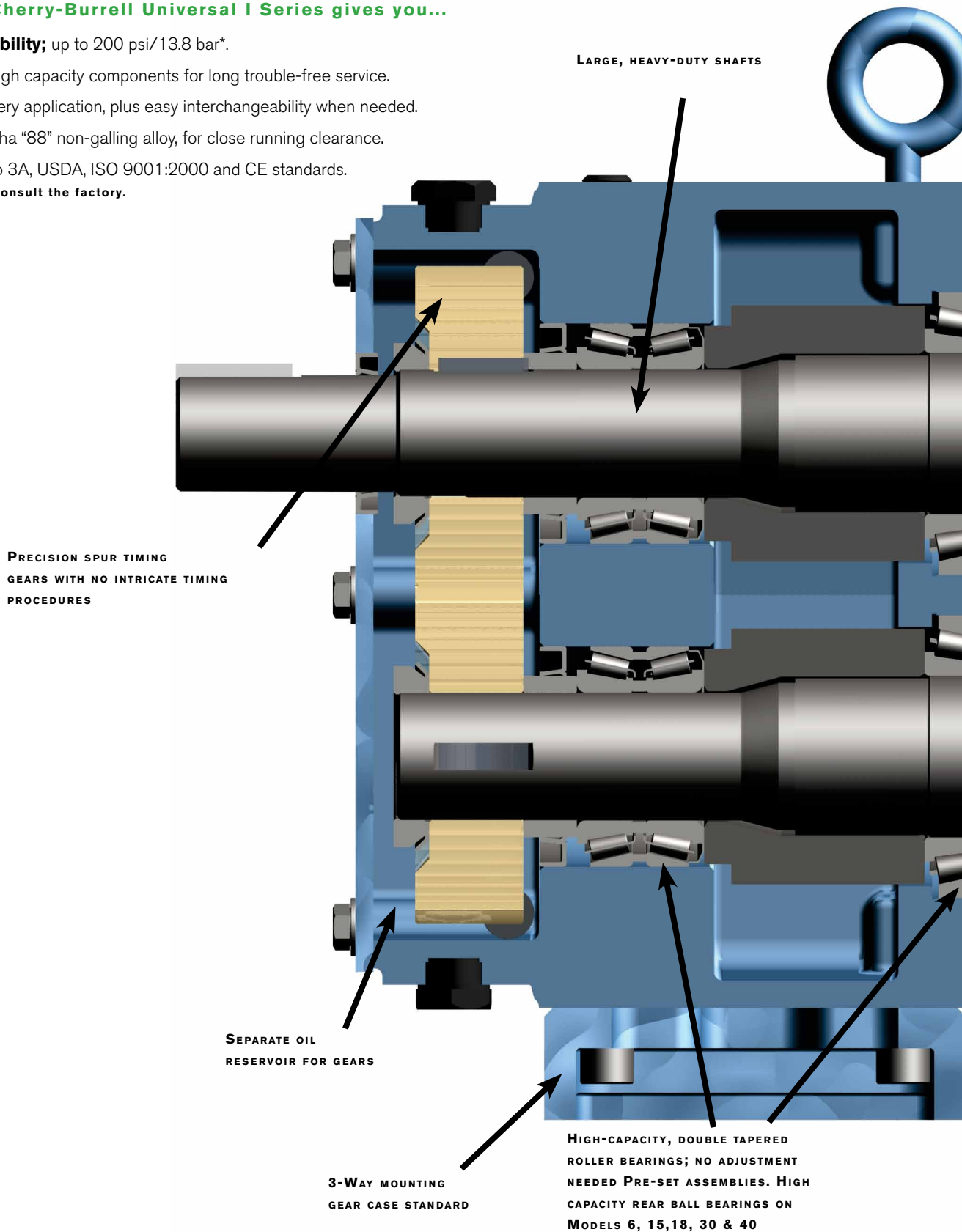

316L STAINLESS STEEL BODY AND COVER; DESIGN CONFORMS TO USDA STANDARDS

FIELD INTERCHANGEABLE SEAL OPTIONS FOR EVERY SERVICE. COMPACT DESIGN KEEPS SHAFT LENGTH TO A MINIMUM.

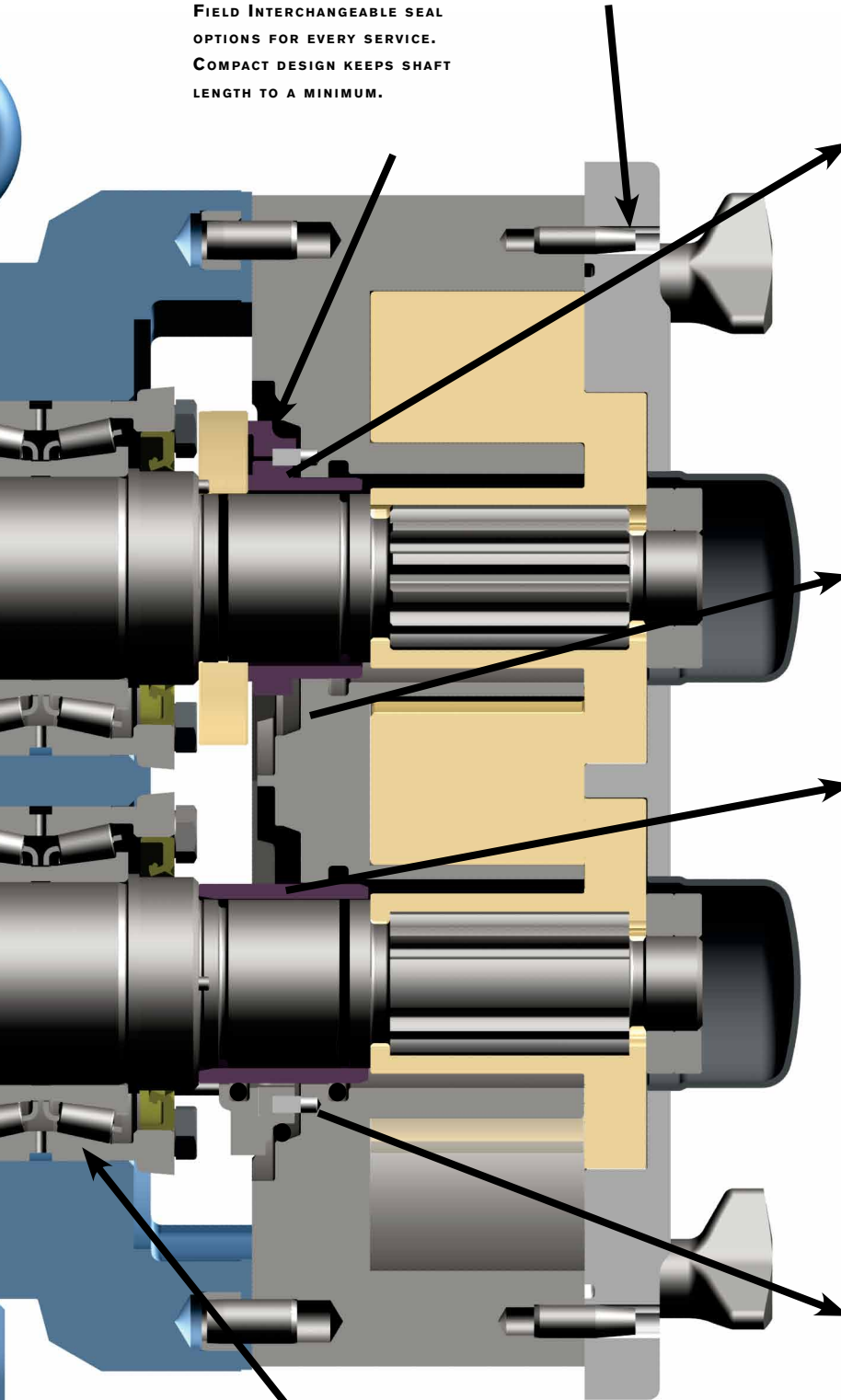

FRONT BEARING FIXED; REAR BEARING FLOATING. BETTER CONTROL OF THERMAL EXPANSION WHEN HANDLING HOT PRODUCTS

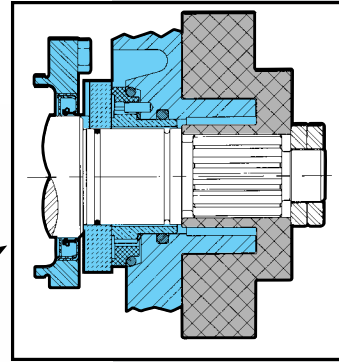

### Double Concentric Mechanical Seal†

Used with flushing fluid to cool, lubricate, flush away residue. Best arrangement for severe service.

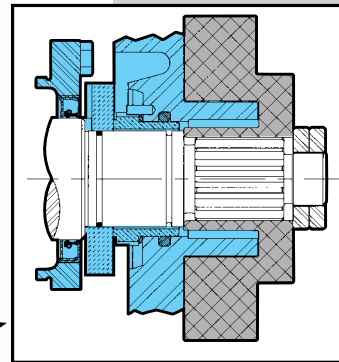

### Single Mechanical Seal†

Longer life, wider pressure-temperature, and speed range than O-ring seal. Alternate materials available for abrasive service.

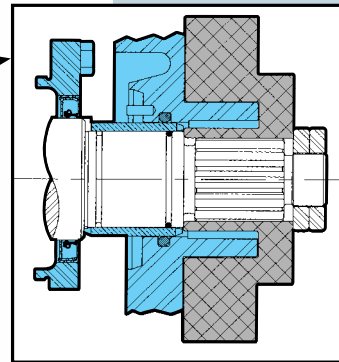

### "O" Ring Seal\*

Waukesha Cherry Burrell's traditional general purpose seal. Low cost and easy to service.

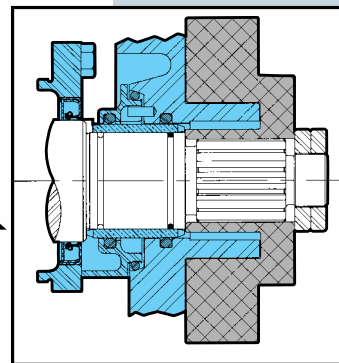

### Double "O" Ring Seal\*

The double, flushed version of the "O" ring seal. Used with flushing fluid to cool, lubricate, flush away residue.

#### Elastomer choices for "O" rings:

- Buna-N
- Fluoroelastomer (FKM)
- EPDM
- Silicone
- Perfluoroelastomer (FFKM)
- PTFE Encapsulated

#### \*Not available for model 320

#### † Mechanical seal material options:

- Carbon
- Ceramic
- Silicon Carbide
- Tungsten Carbide

# Standard & Options

## Body

### **316L SS standard**

#### *Optional:*

- Flush taps for future double seals
- Body retaining screws

## Ports

### **S-Line standard**

#### *Optional:*

- Bevel Seat, I-Line, Q-Line; European DIN, SMS or RJT
- Male NPT, 150 lb. & 300 lb. Flanges. (150 lb. standard on Model 320)
- Rectangular Flange Inlet or Aseptic ports
- Extended ports
- Optional port sizes on 6, 18, 30 and 60 Models

## Covers

### **316L SS plain cover with 3-Wing cover nuts standard**

#### *Optional:*

- Vent or drain connections
- Aseptic, jacketed or vented
- Hex cover nuts

## Rotors

### **Alloy 88 Twin Wing standard. Standard clearance for up to 200° F (93° C)**

#### *Optional:*

- Hot clearance to 300° F (148° C) Clearance above 300° F (148° C) on application
- Special & front face clearances and slotted rotor hub for special applications
- Single wing for 30, 60, 130 and 220 models for minimal particulate damage

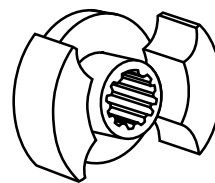

**Twin Wing**

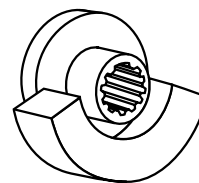

**Single Wing**

## O-Rings

### **Buna-N Standard**

#### *Optional: Fluoroelastomer (FKM), EPDM, Silicone, Perfluoroelastomer (FFKM), FEP Encapsulates*

## Seals

### **Single Buna-N O-Rings with Zirconia sleeve is standard**

#### *Optional:*

- 316L SS sleeve
- Double O-Ring Seal with Flush Connection
- Single Mechanical Seal with Carbon (One Piece) vs. Ceramic Seal Faces
- Double Mechanical Seal with outer Carbon Seal Face & Flush Connections
- Chrome Oxide, Silicon Carbide, & Tungsten Carbide Seal Faces
- Two piece carbon inner seal



**Cast iron special 2-part, blue epoxy paint, 316L SS shafts, top shaft position is Standard.**

*Options:*

- Stainless Steel gearcase
- Steel-It paint
- 17-4 PH shafts
- Lower shaft position
- Bearing Isolators
- Stainless Steel bearing retainers
- Pedestal shims for side mounted pumps. **Left hand shaft position standard**
- Right hand shaft position on side mounted gearcase

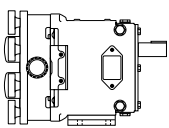

**Top Shaft Position Standard**

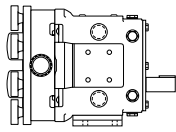

**Lower Shaft Position Optional**

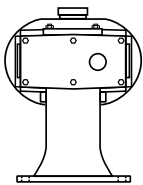

**Standard left hand shaft position shown (right hand optional)**

**Note: Pedestal foot is optional on Standard and Rectangular Flange models. Various standard heights are available and must be specified on order.**

**Optional Side Mount Gear Case for vertical fluid entry**

**Flat plate, epoxy painted, with adjustable feet, SS coupling guard, and Lovejoy or Woods coupling standard.**

*Options:*

- 304 SS unpolished plate base with adjustable feet
- Portable base with rubber wheels
- SS tubular bases

**WCB ISR Integral Speed Reducer Sizes 49, 79 and 239.**

**Direct connected gear motors.**

**Mechanical and Electronic Variable Speed Drives.**

**Hydraulic Motor Drives.**

**Close coupled Tru-Fit™ pump mounted on Epoxy-painted open base.**

*Features:*

- No shaft alignment necessary. No coupling guard required
- Special base design enhances cleanability
- Reduces overall length of complete unit by an average of 20-25%
- Average of 20-25 gear ratios available per horsepower
- Separate oil sump for gear reducer and timing gears

*Options:*

- 304 SS unpolished plate base
- 304 SS polished plate base
- NEMA or IEC frames available. Right angle reducer also available for additional space savings
- 1/2 through 60 horsepower drive options available
- Horizontal or vertical porting

## Gear Cases

## Tru-Fit™

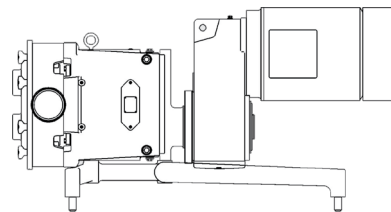

## Bases

## Drives

## DIMENSIONAL DATA

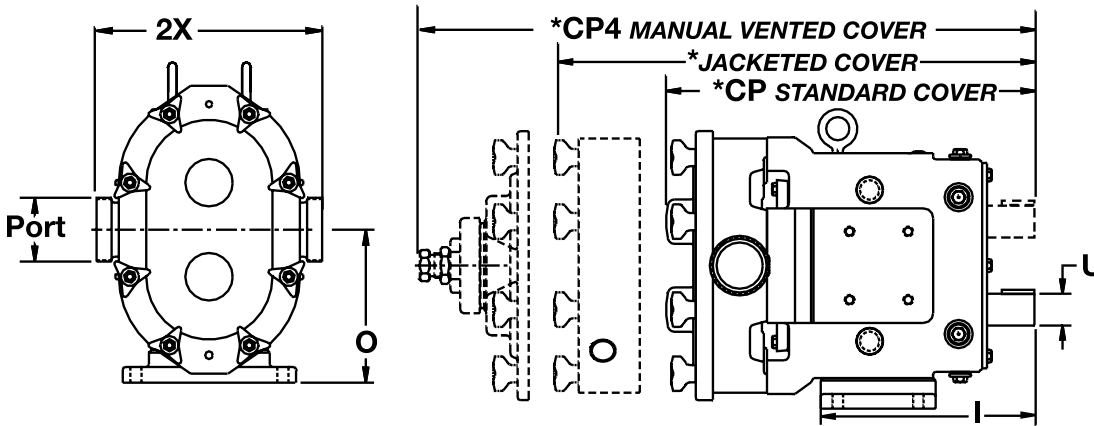

Size Model		CP	CP4	I	O	PORT Size	U +.000 -.001	2X	WT LBS/KG
006-U1	IN	12.04	15.25	7.66	4.21	1 1/2"	.875	6.97	52
	mm	306	387	194	107	---	22.23	177	24
015-U1	IN	12.04	15.25	7.66	4.21	1 1/2"	.875	6.97	52
	mm	306	387	194	107	---	22.23	177	24
018 U1	IN	12.46	15.67	7.66	4.21	1 1/2"	.875	7.09	54
	mm	316	398	194	107	---	22.23	180	24
030-U1	IN	14.58	17.67	8.83	5.21	1 1/2"	1.250	8.50	100
	mm	370	449	224	132	---	31.75	216	45
040-U1	IN	14.96	18.05	8.83	5.21	2"	1.250	8.62	106
	mm	380	458	224	132	---	31.75	219	48
060-U1	IN	18.91	22.07	10.99	7.31	2 1/2"	1.625	10.75	225
	mm	480	561	279	186	---	41.28	273	116
130-U1	IN	19.85	23.01	10.99	7.31	3"	1.625	10.75	260
	mm	504	584	279	186	---	41.28	273	118
220-U1	IN	23.37	27.87	14.80	9.38	4"	2.000	13.25	450
	mm	594	708	376	238	---	50.80	337	204
320-U1	IN	30.17	---	17.80	10.38	6" 150# FLG	2.375	16.00	795
	mm	766	---	452	264	---	60.45	406	361

**NOTE:** Dimension "2X" applies for Bevel Seat, "S-Clamp", "Q-Clamp", 15I and 14I fittings (except 320U1).

**\*NOTE:** CP4 is the maximum dimension for all vented and jacketed cover options.

Contact Application Engineering for Universal I Series Aseptic Models.

**UNIVERSAL 1 MODELS - RECTANGULAR FLANGE**

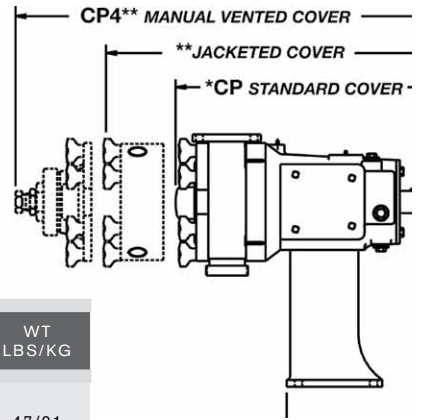
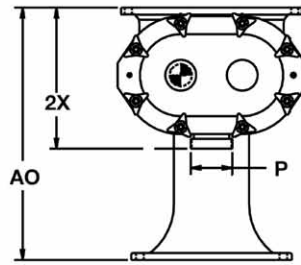

Size Model		AO*	CP	CP4	I	PORT Size	U + .000 - .001	2X	WT LBS/KG
014-U1	IN	12.50	12.04	15.25	7.66	1 1/2"	.875	7.11	47/21
	mm	318	306	387	195	---	22.23	181	
024-U1	IN	12.50	12.46	15.67	7.66	1 1/2"	.875	7.11	49/22
	mm	318	316	398	195	---	22.23	181	
034-U1	IN	14.25	14.58	17.67	8.49	2"	1.250	8.12	100/45
	mm	362	370	449	216	---	31.75	206	
064-U1	IN	19.18	18.91	22.07	10.77	2 1/2"	1.625	10.31	255/116
	mm	487	480	561	274	---	41.28	262	
134-U1	IN	19.18	19.85	23.01	10.77	3"	1.625	10.31	280/127
	mm	487	504	584	274	---	41.28	262	
224-U1	IN	23.75	23.37	27.87	13.74	4"	2.000	12.87	505/229
	mm	603	594	708	349	---	50.80	327	
324-U1	IN	36.00	30.17	---	16.86	6" 150# FLG	2.375	17.88	775/352
	mm	914	766	---	428	---	60.33	454	



\*NOTE: Dimension AO is with tallest pedestal. Optional heights are available.

\*\*NOTE: CP4 is the maximum dimension for all vented and jacketed cover options.

**UNIVERSAL 1 MODELS - TRU-FIT™**

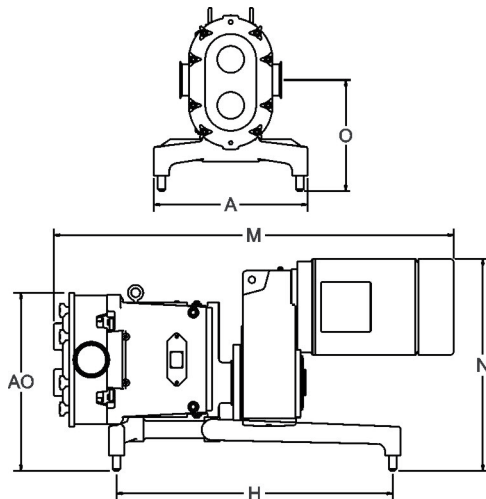

Size Model		A	AO	H	M	PORT Size	N	O
006-U1	IN	12	13.25	18	27.60	1 1/2"	15.56	9.15
	mm	305	37	457	701	---	395	232
015-U1	IN	12	13.25	18	27.60	1 1/2"	15.56	9.15
	mm	305	37	457	701	---	395	232
018-U1	IN	12	13.25	18	28.02	1 1/2"	15.56	9.15
	mm	305	37	457	712	---	395	232
030-U1	IN	14	15.11	20	33.67	1 1/2"	18.65	10.02
	mm	356	384	508	855	---	474	255
040-U1	IN	14	15.11	20	34.04	2"	18.65	10.02
	mm	356	384	508	865	---	474	255
060-U1	IN	18	20.00	28	43.77	2 1/2"	22.02	12.00
	mm	457	508	711	1112	---	559	305
130-U1	IN	18	20.00	28	44.71	3"	22.02	12.00
	mm	457	508	711	1136	---	559	305
220-U1	IN	20	23.25	36	52.25	4"	27.68	14.50
	mm	508	591	914	1327	---	703	368



When it is time to repair ...

SPX offers the following options – you pick the one that meets your needs.

#### Factory Remanufacturing Program

- No need to return your pump until you receive your new replacement pump.
- Substantial savings over new pump.
- All remanufactured pumps must pass a 25 point inspection process and undergo performance testing.
- Only OEM genuine parts are used in the remanufacturing process and you receive a guaranteed warranty and quality certificate with each pump.
- New pumps eligible for Remanufacturing Program twice.

#### Factory Inspect and Advise Program

- Return your pump for complete factory inspection.
- Cost effective options to match your performance/budget needs.
- Your pump body may be remachined up to 6 times.
- Replacement rotors and parts available.
- Factory warranty.

#### SPX Certified Pump Repair Centers

- Local distributors with factory trained and certified service technicians.
- Quick local response.
- Genuine WCB parts.
- Flexible repair programs to meet your needs.
- Local warranty.

#### SPX Warranty

**Seller warrants its products to be free from defects in materials and workmanship for a period of one (1) year from the date of shipment. This warranty shall not apply to products which require repair or replacement due to normal wear and tear or to products which are subjected to accident, misuse or improper maintenance. This warranty extends only to the original buyer. Products manufactured by others but furnished by seller are exempted from this warranty and are limited to the original manufacturer's warranty.**

#### SPX FLOW TECHNOLOGY

611 Sugar Creek Road  
Delavan, WI 53115  
P: (262) 728-1900  
F: (262) 728-4904  
E: wcb@spx.com

SPX reserves the right to incorporate our latest design and material changes without notice or obligation.

Design features, materials of construction and dimensional data, as described in this bulletin, are provided for your information only and should not be relied upon unless confirmed in writing. Please contact your local sales representative for product availability in your region. For more information visit [www.spx.com](http://www.spx.com).

The green ">" is a trademark of SPX Corporation, Inc.

ISSUED 1/2012 FH-1701

COPYRIGHT © 2012 SPX Corporation