

Product Profile

Magnet drive, end suction, centrifugal pumps for the Petroleum and Heavy Chemical Industries.

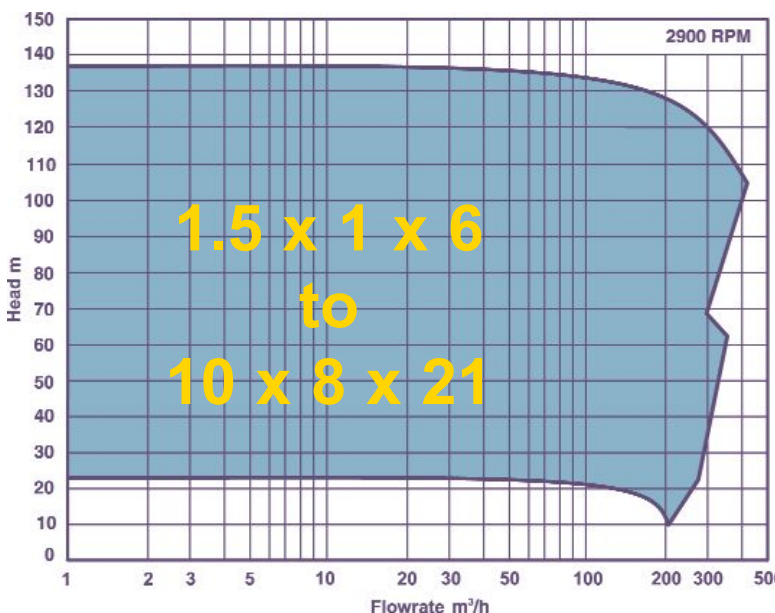

HMD/Kontro have been building Magnetic Drive pump units to API codes since 1984, starting first with API 610 6th edition and then modifying designs to incorporate 7th and 8th edition requirements.

October 2000 saw the official release of API 685, a code dedicated to Seal/less pumps and once again HMD/Kontro are at the forefront with their GSP models.

Pump users industry-wide have had their say, and their comments and requests have been applied throughout the specification. With our 17 years API experience and our 50 year heritage in magnetic drive technology backing us HMD/Kontro are in ideal position to provide your pump requirements for Refinery and Heavy Duty Chemical services.

Our range of API 685 pumps is being continuously developed and extended and currently stands at over 30 sizes.

Paragraph 6.5.1
Flanges conform to Nozzle Load requirements.

Paragraph 6.7.1
Renewable Wear Rings.

Paragraph 6.10.5
Grooved bearings for heavy
removal and particle flush

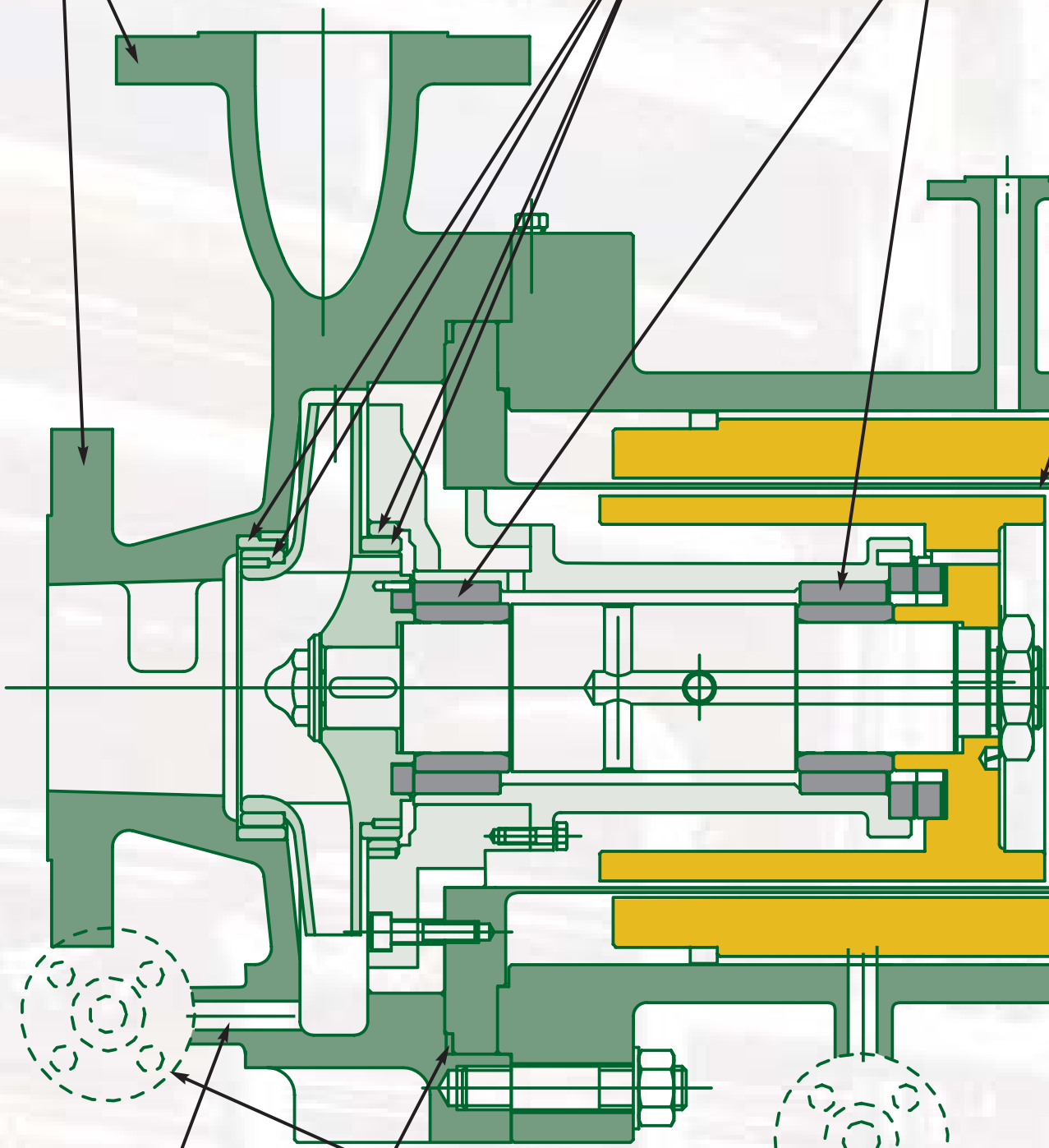

Paragraph 6.1.8
All internal cavities
must be drainable.

Paragraph 6.3.5
Single confined controlled
compression gasket.

Paragraph 6.4.3.1
Field connections shall
terminate in a flange

API 685

Paragraph 9.1.2.1

Containment shell constructed in accordance with ASME VIII code for pressure vessels.

Paragraph 6.9.3.7

Bearing housing dimple for vibration monitoring.

- Alpha SiC Internal Bearings
- High Efficiency Magnet Drive
- Single Gasket
- Temperatures up to 750°F/400°C
(No cooling required)
- Working Pressure 580 psi/40 bar
- 17 Years API Experience
- Non Sparking Bump Ring

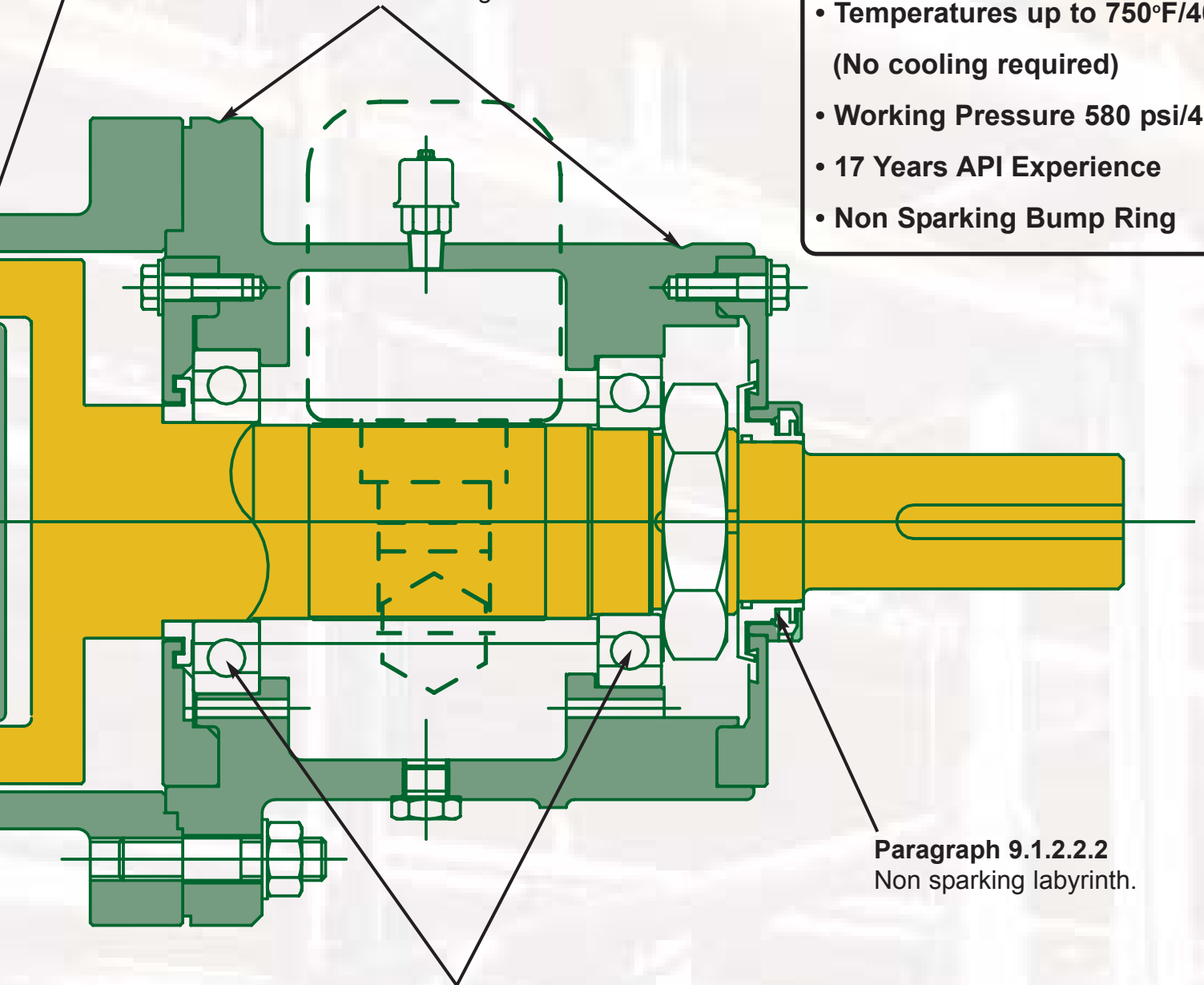

Paragraph 9.1.2.2.2
Non sparking labyrinth.

Paragraph 4.1.4.1.1

Bearings to L10
50,000 hours.

Paragraph 6.3.8
Centerline supported casings shall be used.

Users include

- Esso
- Statoil
- BP Amaco
- Exxon
- ICI
- Petronas
- Pemex
- Shell
- BASF
- Texaco
- Phillips

Liquids handled

- Acrylic Monomers
- Acrylonitrile
- Amyl Acetate
- Aromatics
- Benzene
- Butadiene
- Butane
- Chloroform
- Cyclohexane
- Dichlorobenzene
- Ethylene
- Hexane
- Kerosene
- LPG
- MDI
- Methylene Dichloride
- Methyl Naphthalene
- MMA
- Naphtha
- Naphthalene
- Pentane
- Phenol
- Pyridine
- Pyrogallic Acid
- Styrene
- Sulphuric Acid
- TDA
- TDI
- Toluene
- Trichloroethylene
- Vinyl Acetate
- Various Chlorinated Hydrocarbons
- Xylene

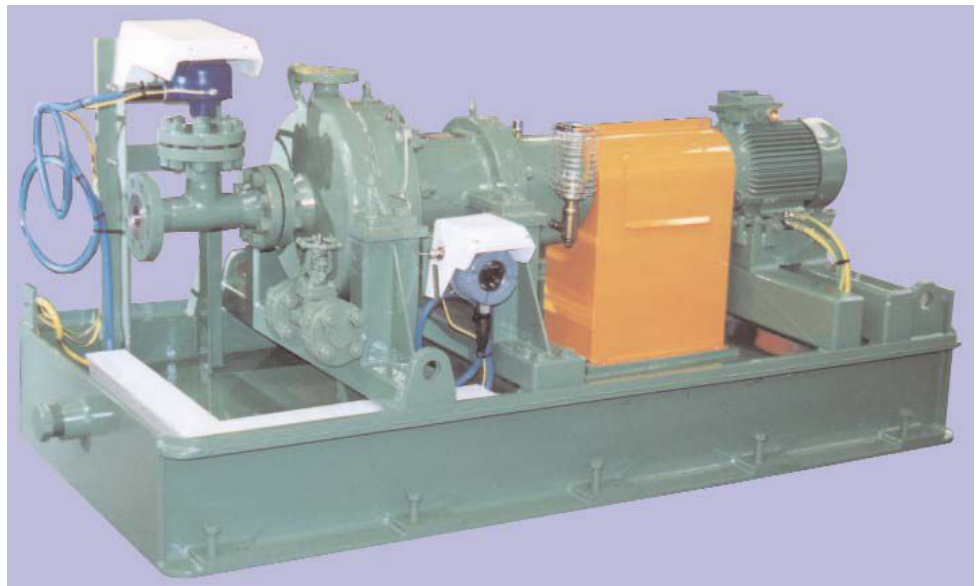

Optional Instrumentation Packages available

Internal Pressure / Temperature Profiles Available

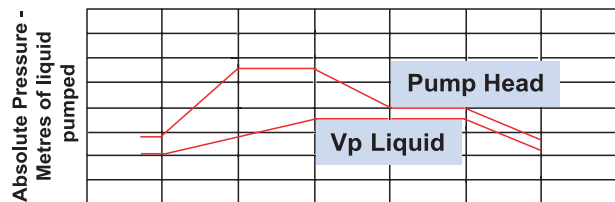
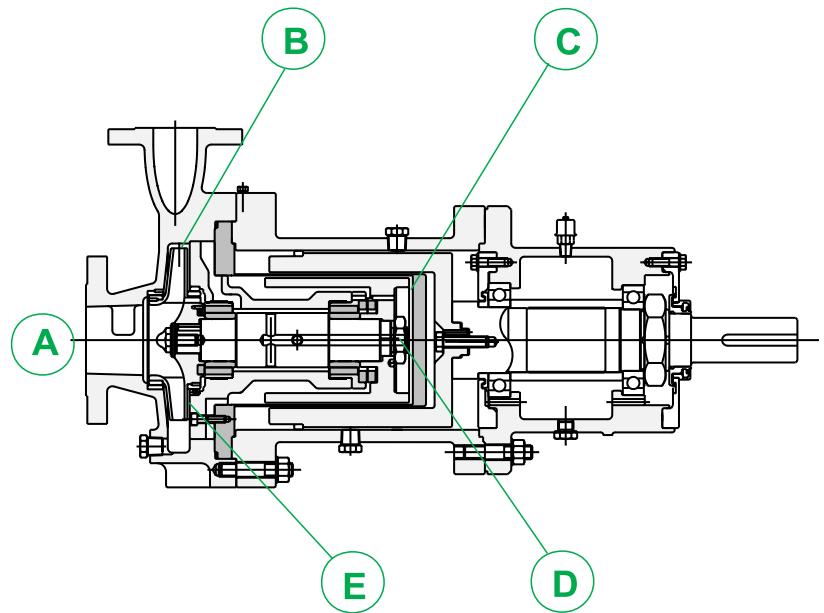

Temperature Rise - Absolute Pressure - Vapour Pressure Characteristics of internal feed system



Sealless Pumps



HMD Seal/less Pumps Ltd. Brampton Road, Hampden Park Industrial Estate, Eastbourne, East Sussex, BN22 9AN, England

Tel: 01323 452000 Fax: 01323 503369 Tel: (Int) +44 1323 452000 Fax: (Int) +44 1323 503369 email: pumps@hmdpumps.com

www.hmdkontro.com

© HMD Seal/Less Pumps Ltd. 2001

Ref:API685-2001 Issue 1.0 11/01