

Food & Pharmaceutical Technology, Market and Applications



Business Field Food & Pharmaceutical Products and Components

You've got the Application, we've got the Solution

Within the business unit PUMPS, Food & Pharmaceutical holds a crucial position all over the world with regard to uncompromising hygiene and the most demanding process requirements in all manufacturing areas.

Business Field Food & Pharmaceutical

- Food industries
- Pharmaceutical
- Cosmetic products
- Bio-technology
- Chemical
- And similar



We have our Finger on the Pulse.

Products should keep fresh for a longer period of time but still maintain their original quality standard. Our pumps as the "driving force" in your production process are a key ingredient of your product quality.

We develop, manufacture and sell positive displacement pumps which ensure in all process stages a sanitary and smooth process of high quality and shear-sensitive fluids.

Driving Forces.

Two different types of pumps are available for various process requirements: NEMO® Sanitary and Aseptic Progressing Cavity Pumps and NETZSCH TORNADO® Sanitary Rotary Lobe Pumps.

Engineering Partnerships.

With our customers from all over the world we are able to incorporate the latest market trends and requirements into the development and improvement of our products. Therefore new possibilities for your manufacturing process continually arise.

NEMO® Progressing Cavity Pumps

Sanitary pumps
Sanitary plus pumps
Sanitary mini plus pumps
Aseptic pumps

TORNADO® Rotary Lobe Pumps

Sanitary rotary lobe pumps

NETZSCH Accessories

Protection devices
Flushing/Sealing pressure devices
Control systems
Trolley assemblies
Tools



General Features of the NEMO[®] Sanitary- and Aseptic Progressing Cavity Pumps

General

The sanitary design of components and machinery as well as the cleanability of process plant are defined in a multitude of rules and regulations. NEMO[®] Pumps are constructed, manufactured and tested according to EHEDG regulations (European Hygienic Equipment Design Group) or QHD regulations (Qualified Hygienic Design). The materials used are certified in accordance with FDA (Food and Drug Administration), BfR (Bundesinstitut für Risikobewertung) and PL (Positive List / Japan).

Additionally, NEMO[®] Sanitary and Aseptic Progressing Cavity Pumps are certified according to the 3-A Sanitary Standards of the US and GOST-R (Russian Certificate of Conformity).

Large Range of Capacities and Pressures

- Flow rates from 600 gpm or 140 m³/h
- Pressures up to 360psi / 24 bar

Wide Range of Applications

NEMO[®] Sanitary and Aseptic Progressing Cavity Pumps are normally used for fluids having the following properties:

- Shear-sensitive
- Of low up to high viscosity
- Smearing and non-smearing
- With or without solids
- Dilatant or thixotropic
- Abrasive
- Adhesive

Advantages

- Smooth delivery
- Long process cycles due to contamination proof and sterile design
- Suitable for CIP and SIP
- Almost pulsation-free pumping
- Food quality mechanical seal in a housing bolted directly to the pump suction body allowing operation in both directions up to the maximum pump pressure
- Flow rate in proportion to speed with high dosing accuracy over a wide speed range
- Flow rate independent of variances in pressure or viscosity
- Product intake possible in vacuum conditions up to almost total vacuum
- The crevice free housing designed for good flow condition avoids settling of the fluid
- Conical shaped stator inlet for optimal filling of the pumping chambers
- All contact surfaces in polished version to avoid caking of the fluid and to facilitate cleaning
- For lubricating fluids, open, patented, sanitary joints
- Version with flexible rod for uncompromising hygiene and long serviceable life
- Elastomers in food standards according to BfR, FDA and PL
- Heating of housing and stator (optional)
- Horizontal or vertical installation
- Service friendly

CIP/SIP Process

For the CIP process, the entire system requires a cleaning fluid velocity of at least 5 ft/sec or 1.5 m/s and to facilitate this the NEMO® Sanitary and Aseptic Pro-gressing Cavity Pumps are equipped with additional cleaning ports. The position of these ports can be determined to suit the application and they require a bypass pipe.

The bypass is also required for the SIP process. In both the CIP and SIP processes the NEMO® pumps are operated intermittently.

Tangential cleaning ports guarantee complete emptying of the NEMO® pump. All pump materials used are suitable for CIP- and SIP processes.

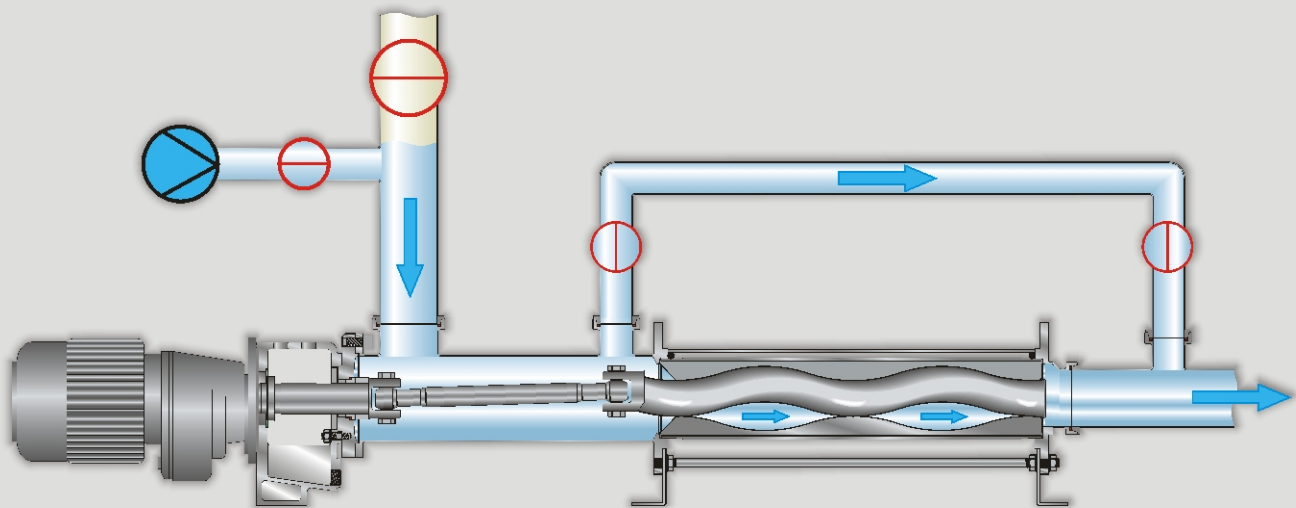

 CIP-pump

 CIP-medium

 valve open

 valve closed

Construction of the NEMO[®] Sanitary Pump in Block Construction Design

Flexible Rod

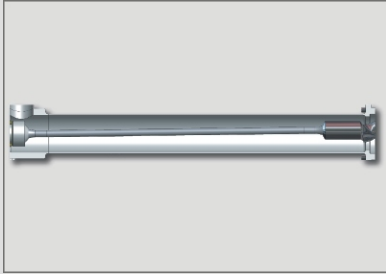

The flexible rod for universal use in the NEMO[®] Sanitary Plus series is corrosion-proof, crevice free, wear- and maintenance free because there are no components moving against each other as in other joint types. Neither lubrication nor seals are required so that the lubricity of the fluid does not have to be taken into consideration. Ideal for pumping highly sensitive products with or without solids and for uncompromising sanitary applications. Also available as a 3-A flexible rod.

Feeding Screw Hopper

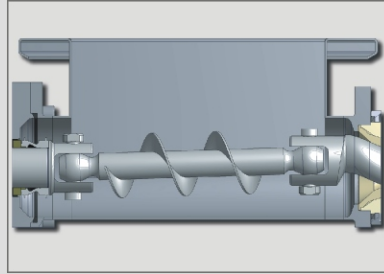

For highly viscous and pasty products, the pump is optionally equipped with a feeding screw and a hopper to allow for an optimal filling of the pumping chambers.

Heating Rail and Thermal Jacket

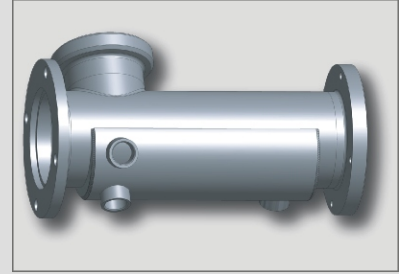

Optional version with pump housing and stator which can be heated or cooled.

Mechanical Seal with Elastomer Bellows

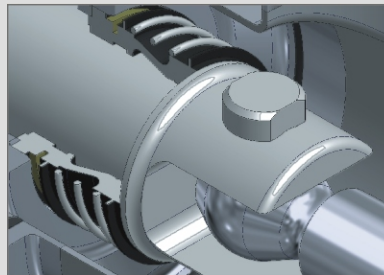

Single seal, unbalanced, independent of direction of rotation, elastomere bellows seal faces with or without knife edge. Seal faces in SIC. On request elastomer in compliance with FDA standards.

Mechanical Seal with Encapsulated Spring

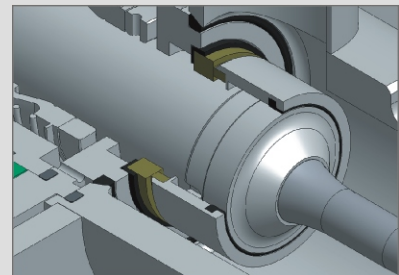

Single seal, balanced, independent of direction of rotation, with product protected spring. Smooth surface. Seal faces in SIC. Elastomer in compliance with FDA standards.

Components of the NEMO® Progressing Cavity Pump e.g. the NEMO® Block Pump in Sanitary Design

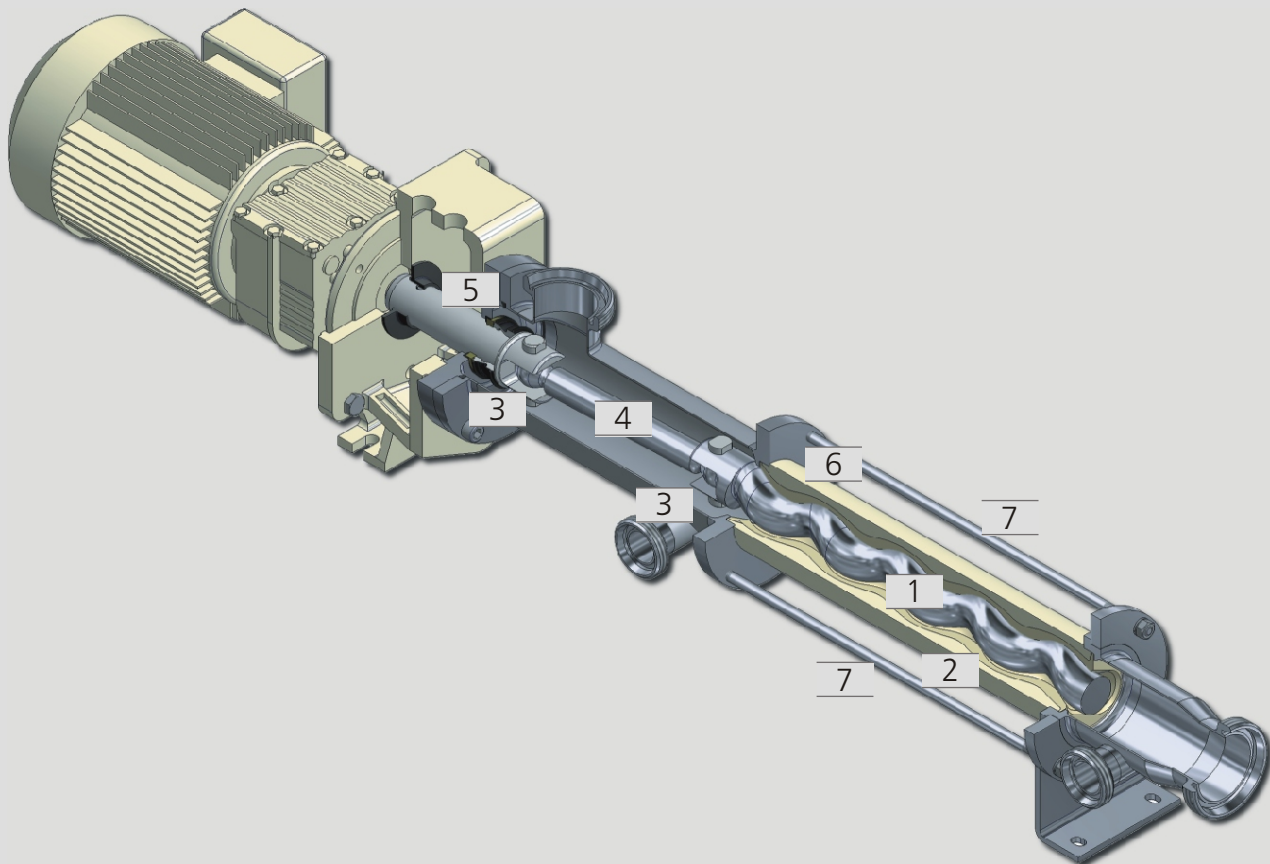

1 Rotor

2 Stator with Reduced Wall Thickness

For changing product temperatures a patented stator with reduced elastomer wall thickness is used. In addition, a thermal stator protector (STP-3 or STP-D) for overheating and dry running protection is available.

3 Sanitary Joints

Patented, open crevice free sanitary joints for optimal cleaning.

4 Drive Chain

Drive and connection shaft with coupling rod and two sanitary joints for drive transmission to the rotor.

5 Sealing Housing

Food quality mechanical seal in a housing screwed directly to the pump suction body allowing pumping in both directions up to the maximum pump pressure.

6 Stator Jacket

In stainless steel (optional).

7 Stator Bolts

In stainless steel.

Construction of the NEMO[®] Aseptic Pump with Bearing Housing

Double Mechanical Seal in Tandem Arrangement

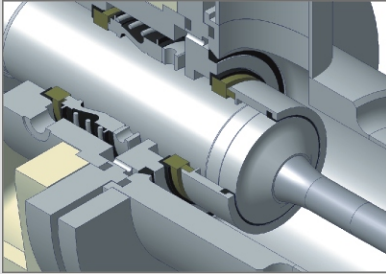

Double mechanical seal faces in tandem arrangement with unpressurized, static or dynamic quench. Mechanical seal faces in SIC. Elastomer in compliance with FDA standards. The design of the rotating unit guarantees the seal integrity at changing temperatures and pressures. The seal complies with EHEDG and QHD regulations.

Pipework (optional)

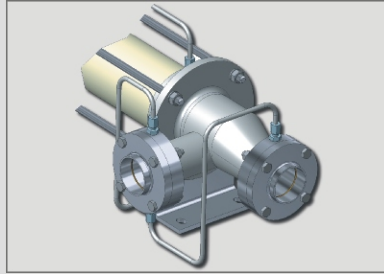

The pipework circulates sterile condensate, vapor and/or detector fluid to the double acting, closed seal lines.

Flexible Rod

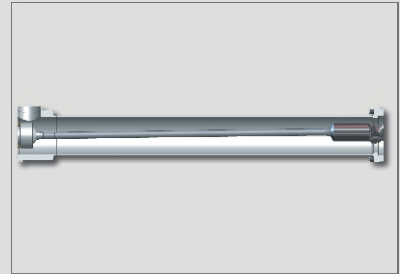

The patented flexible rod is corrosion-proof, wear and maintenance-free because there are no components moving against each other as in other joint types. Neither lubrication nor seals are required so that the lubricating capability of the fluid does not have to be taken into consideration. Ideal for shear sensitive fluids with or without solids and for uncompromising sanitary and aseptic applications.

Components of the NEMO® Progressing Cavity Pump e.g. the NEMO® Aseptic Pump with Bearing Housing

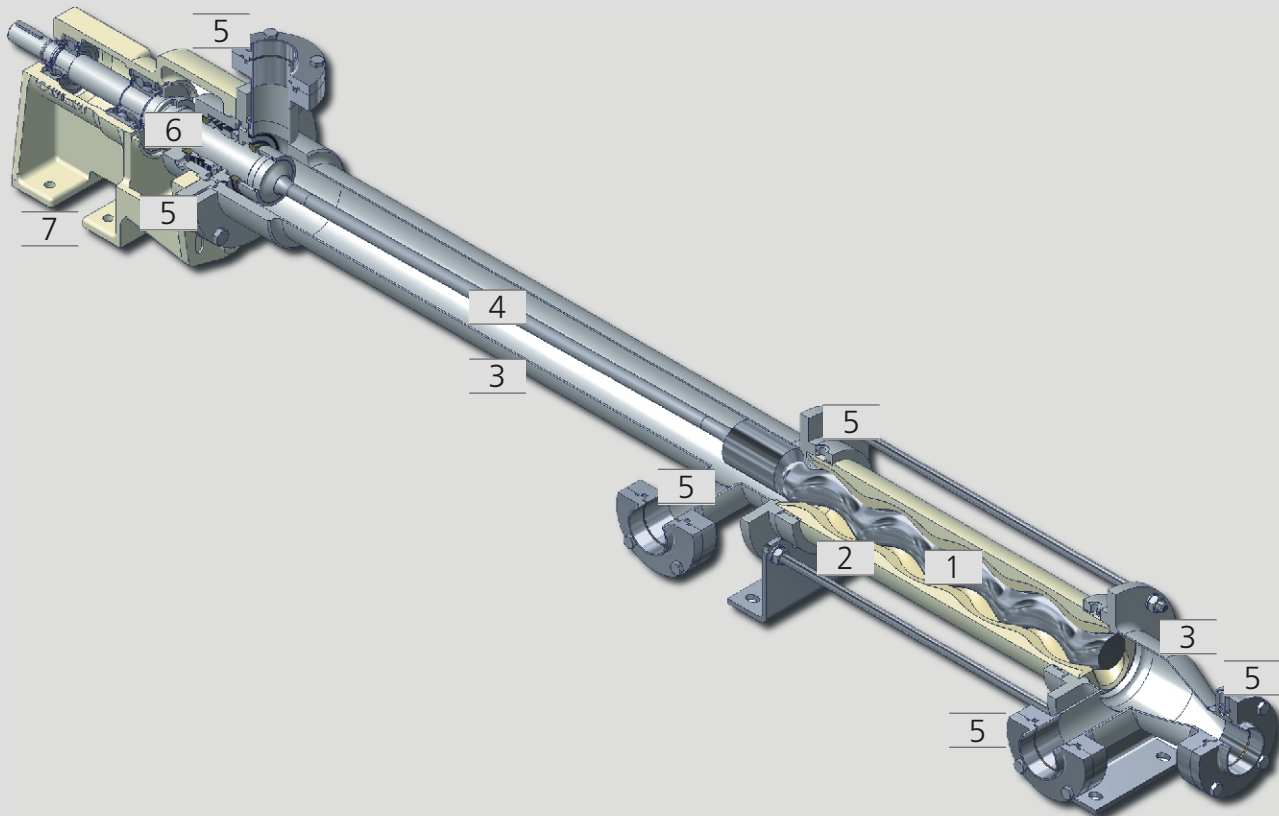

1 Rotor

2 Stator with reduced Wall Thickness

For changing product temperatures a patented stator with reduced elastomer wall thickness is used. In addition, a thermal stator protector (STP-3 or STP-D) for overheating and dry running protection is available.

3 Housing / Discharge Flange

The pump housing has a reduced diameter for optimal flow velocity and minimized pump volume. The body flange is located directly above the shaft seal removing any dead flow areas. Therefore the deposit of fluid in the housing during the manufacturing cycle is eliminated.

4 Flexible Rod

5 Double, buffered, static seals

All static seals to the atmosphere are double sealed chambers. Sterile condensate, vapor and/or detector fluid is continuously supplied to the chambers. Through the contamination-proof design the process cycle can be reduced by the removal of some sterilization processes. Consequently output capacity increases as the number of cleaning cycles decreases.

6 Sealing Housing

Food quality mechanical seals in a housing screwed directly to the pump suction body allow pumping in both directions up to the maximum pump pressure.

7 Bearing Housing

Widely spaced, heavy duty bearings ensure optimum concentricity of the drive shaft and are able to withstand large axial loads. The free shaft end allows for the use of all types of drives.

General Features of the NETZSCH TORNADO[®] Sanitary Rotary Lobe Pump

General

The sanitary design of components and machinery as well as the self-draining cleanability of parts of a plant are defined in a multitude of rules and regulations.

Moreover, NETZSCH TORNADO[®] Sanitary Rotary Lobe Pumps are certified in line with the 3-A Sanitary Standards of the US.

CIP/SIP Process

For the CIP process, in the whole system the cleaning fluid should have a flow velocity of at least 5 ft/sec or 1.5 m/s, thus, NETZSCH TORNADO[®] Sanitary Rotary Lobe Pumps may also be used as cleaning pumps, i.e. delivery and cleaning with the same pump. All materials are in line with CIP- and SIP processes.

Large Range of Capacities and Pressures

- Flow rates up to 660 gpm or 150 m³/h
- Pressures up to 180 psi / 12 bar

Wide Range of Applications

NETZSCH TORNADO[®] Sanitary Rotary Lobe Pumps are normally used for fluids having the following properties:

- Shear sensitive
- With or without solids
- Medium up to high viscosity (300 cps to 100,000 cps and higher)
- Thixotropic and dilatant
- Lubricating and non lubricating
- Adhesive

Advantages

- Compact design, high performance
- Suitable for a wide temperature range
- Resistant to dry running
- Smooth delivery
- Flow rate in proportion to speed
- Direction of rotation, thus, direction of flow reversible
- Vibration free and quiet running
- Capable of CIP and SIP
- Enlarged inlet cross section for highly viscous fluids (optional)
- Easy maintenance of the pumping elements and shaft seal without having to remove the pump from the pipe

Construction of the NETZSCH TORNADO® Sanitary Rotary Lobe Pump

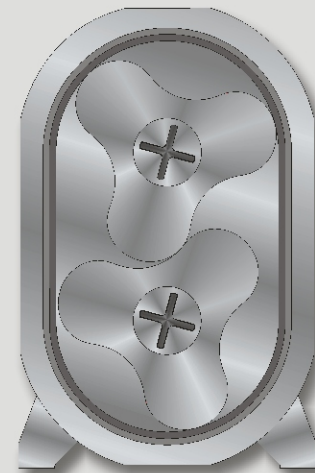
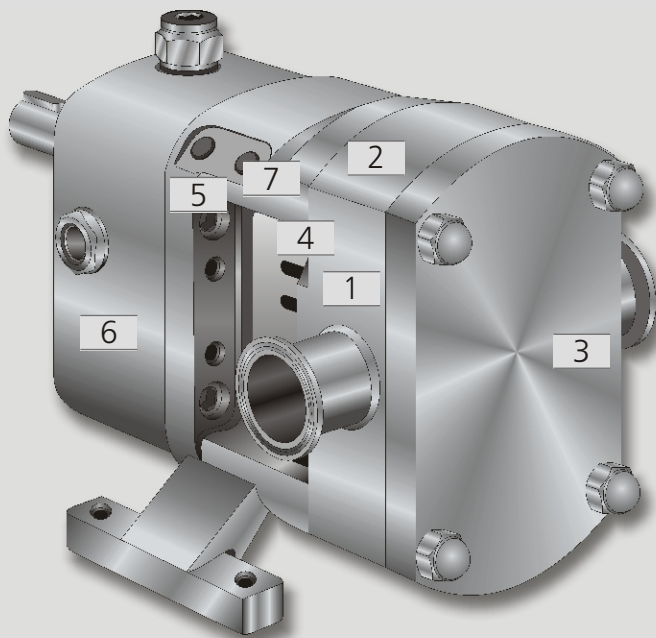

1 Rotor

Depending upon the application, three and four wing lobes are used as rotating elements.

2 Pump Housing

Product inlet ports are designed for good flow conditions. Better flow into the rotary lobes. Pump connections horizontally or vertically positioned for complete emptying.

3 Housing Cover Plate

Rotary lobe and shaft seal are easily accessible through the housing cover and can be maintained or exchanged without having to remove pump housing or piping.

4 Shaft Seal

Standard design is with single acting mechanical seal independent of the direction of rotation. On request various types of single/double acting mechanical seals, special seals, as well as stuffing boxes are available.

5 Timing Gear

The helical gears allow for precise positioning of the rotary lobes and guarantee quiet running.

6 Gear Housing

Gear housing completely made from stainless steel and is easily disassembled. Even components of both the pump housing and the synchronized gear housing which are not in contact with the fluids are made from stainless steel, i.e. best suitable for use in sanitary applications.

www.netzsch.com

NETZSCH Pumps North America, LLC
119 Pickering Way
Exton, PA 19341
USA
Phone: 610 363-8010
Fax: 610 363-0971

E-mail: npa@netzsch.com
www.netzsch.com

NETZSCH Canada, Incorporated
740 Huronia Road, Unit 10
Barrie, ON L4N 6C6
Canada
Phone: 705 797-8426
Fax: 705 797-8427

E-mail: ntc@netzsch.com
www.netzsch.com
