

# Dynamically Sealed AHLSTAR Process Pumps

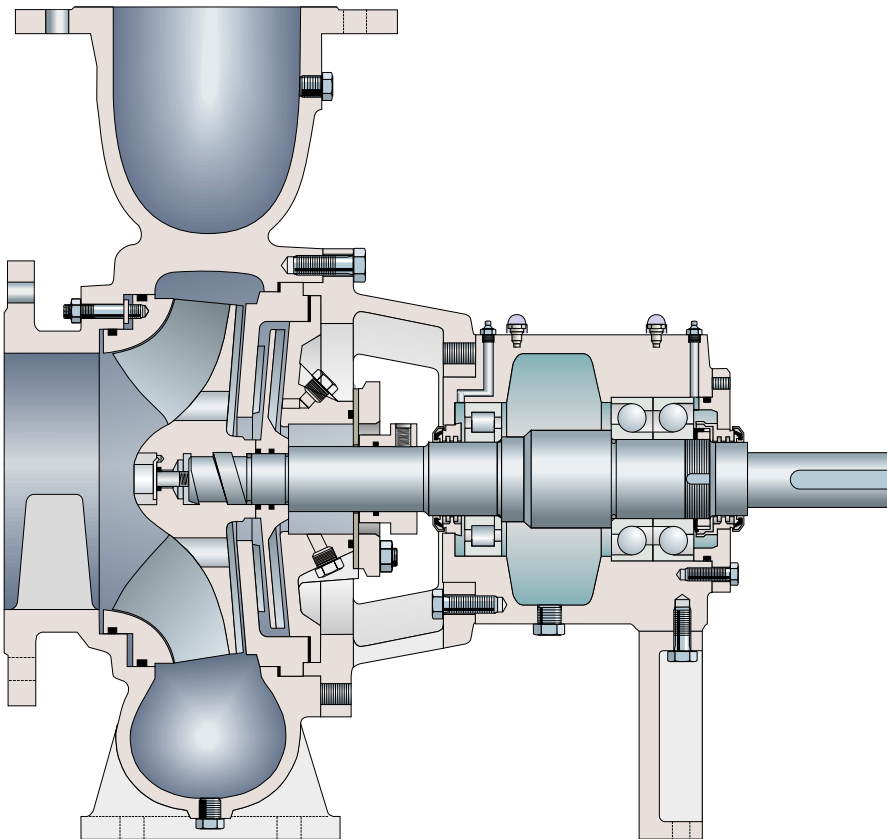

The Heart of Your Process

# Dynamic Seal for AHLSTAR A, APP/APT, NPP/NPT and WPP/WPT Pumps

Extends mean time between planned maintenance (MTBPM) while eliminating expensive mechanical seals and reducing high maintenance costs.

Until now, the shaft seal has been the most maintenance intensive component of a centrifugal pump. While the use of a mechanical seal instead of a packed stuffing box for stock and other difficult liquids has brought considerable improvements, significant operating and maintenance problems remain.

Conventional cord packings and mechanical seals will wear due to mechanical friction during running and will eventually form a leak path. These seal types require a steady supply of sealing liquid for lubrication and cooling and often this liquid comes from an outside source. Therefore, frequent maintenance is a necessity and the selection of mechanical seals has to be done very carefully.

Mechanical wear, leakage and the need for sealing liquid have been practically eliminated with the introduction of the Dynamic Seal for AHLSTAR pumps. The Dynamic Seal is used not only for all stock consistencies but also for other difficult liquids containing solids.

## Simple Operation

When the pump is running, the expeller generates centrifugal forces which form a liquid ring in the expeller seal chamber. This liquid ring becomes the shaft seal and prevents leakage.

The expeller rotates freely in its chamber without any mechanical friction and also without mechanical wear. When the pump stops, the liquid fills the seal cavity and presses the flexible disc against the sleeve, thus preventing leakage.

When the pump starts again, the expeller generates a liquid ring in the expeller seal chamber and removes the liquid from the seal cavity. The flexible disc is no longer pressed against the sleeve.

## Conversion of Existing Pumps to Dynamic Seal

Existing AHLSTAR A, APP/APT, NPP/NPT or WPP/WPT pumps, originally installed with a mechanical seal or stuffing box packing, can easily be converted to the Dynamic Seal.

No machining is necessary. All that is required is an interchange of parts. Overall, pump dimensions are the same, so the pump and the motor remain in the installed position.

The conversion kit includes the expeller, casing cover, seal chamber, complete static seal and all necessary O-rings and gaskets.

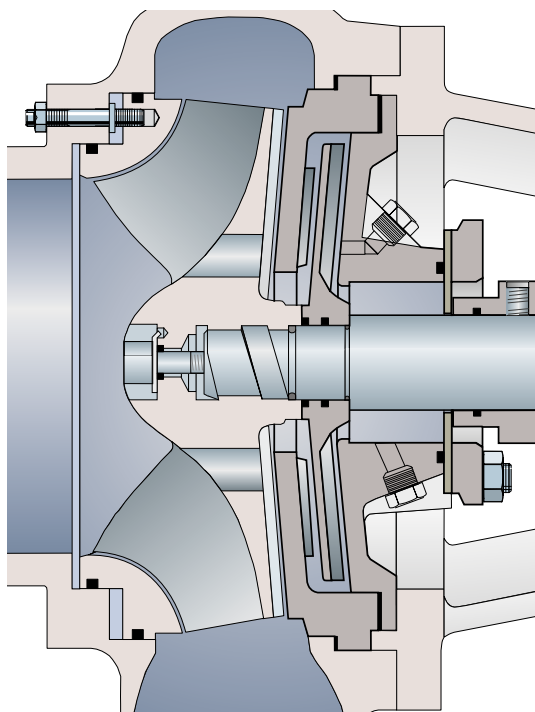

# Dynamic Seal Provides Reliable Operation

## Expeller is designed for stock consistencies up to 8 %

- No mechanical wear
- No clogging

## Diffuser vanes

- Guide solids back to the pumped liquid
- Liquid interchange

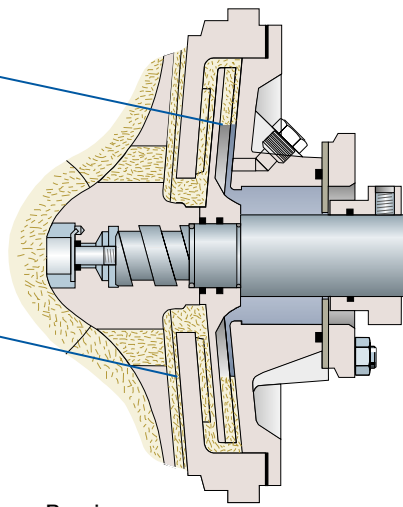

Running.

## No sealing water

- Flushing is possible in special cases

## Flexible disc provides static seal

- No mechanical wear when the pump is running
- Disc and sleeve are in contact only during standstill
- Easily adjustable gap

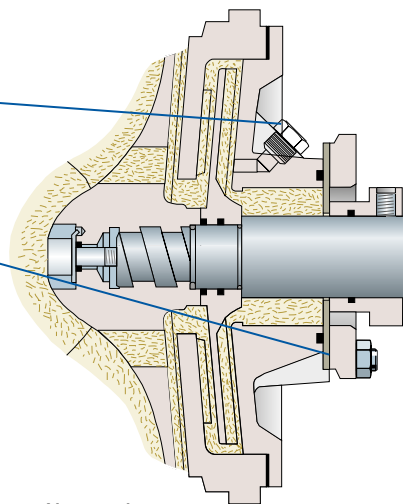

Not running.

## New Options

The well proven and highly successful Dynamic Seal has been given a new generation of additional properties. With the latest construction, we are able to enlarge its operational limits, and low or occasionally high liquid level pump suction and even light vacuums, can now be handled.

# Frequently asked questions

## Are there any limitations on higher consistencies?

The Dynamic Seal, developed by Sulzer Pumps for AHLSTAR pumps, can be used for all consistencies where A, APP/APT, NPP/NPT and WPP/WPT pumps are normally used.

## What happens when pumps are stopped for a longer period?

Usually, systems are flushed before a longer stop. This is normally sufficient to clean the seal chamber of the Dynamic Seal. A short stop does not require flushing.

## Why is there a flushing connection?

There are liquids in certain process industries where pumps have to be cleaned quickly and thoroughly also before a short stop.

## Is the Dynamic Seal economical?

Neither sealing liquid nor sealing water systems for pumps are necessary. This contributes to lower waste water treatment costs and lower evaporation costs in evaporator applications. Although power consumption is slightly higher than in conventional systems, service life is longer and maintenance costs are considerably lower.

## Are there other limits?

The minimum pressure at the hub of the expeller is the atmospheric pressure. The maximum inlet head depends upon the speed and the diameter of the expeller.

[www.sulzer.com](http://www.sulzer.com)

E00530 en (5) 8.2012 (1,000), Copyright © Sulzer Pumps

This brochure is a general presentation. It does not provide any warranty or guarantee of any kind. Please, contact us for a description of the warranties and guarantees offered with our products. Directions for use and safety will be given separately. All information herein is subject to change without notice.