

ABS SCAVENGER® SUBMERSIBLE EFFLUENT AND SEWAGE EJECTOR PUMPS

60 Hz

Rugged Submersible pumps for residential and commercial applications.

ABS submersible pumps series Scavenger are suitable for two main applications:

- Effluent Models - used for both low and high pressure dosing systems and light duty industrial sumps.
- Ejector Models - used for septic tanks and sewage systems, light agricultural usage and residential, industrial commercial light trash handling.

1/3, 4/10 & 1/2 HP

- High torque capacitor motors.
- 2" NTP vertical discharge, vortex impellers
- Rugged cast iron housing
- Stainless steel fasteners and motor shaft
- Oil filled motors (non-toxic oil)
- Integrated clip for float switch cable
- Available with or without ABS piggyback float switch



3/4 HP & above

- Unique triple seal design
- ABS Patented ContraBlock® impeller with adjustable wear plate system, for clog-free operation
- Single phase models through 5HP, Three phase models through 10HP
- Discharges, 1 1/4 to 4"
- Oil filled motors (non-toxic oil)
- High torque capacitor start single phase motors
- Rugged cast iron construction with stainless steel fasteners and motor shaft



ABS SCAVENGER® SUBMERSIBLE EFFLUENT AND SEWAGE EJECTOR PUMPS

Effluent Pumps 1 1/4 Inch

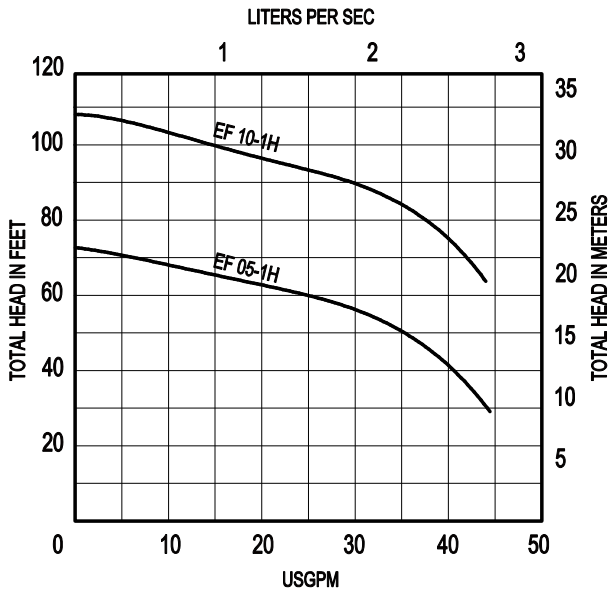

Effluent Pumps 2 Inch

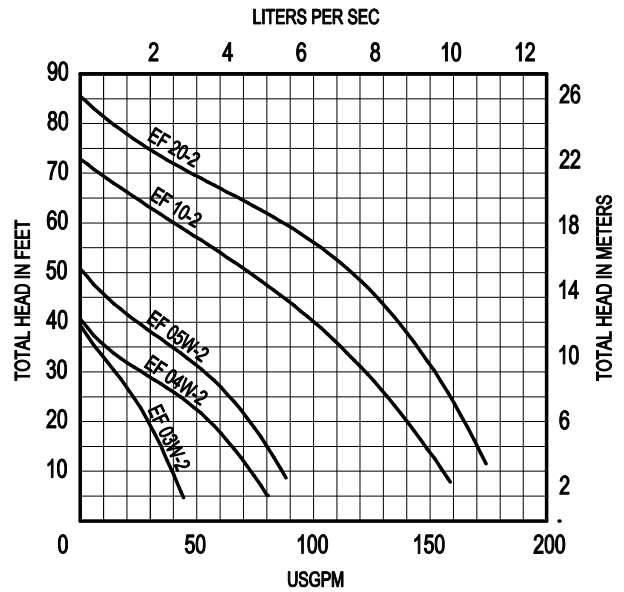

Sewage Ejectors 2 Inch

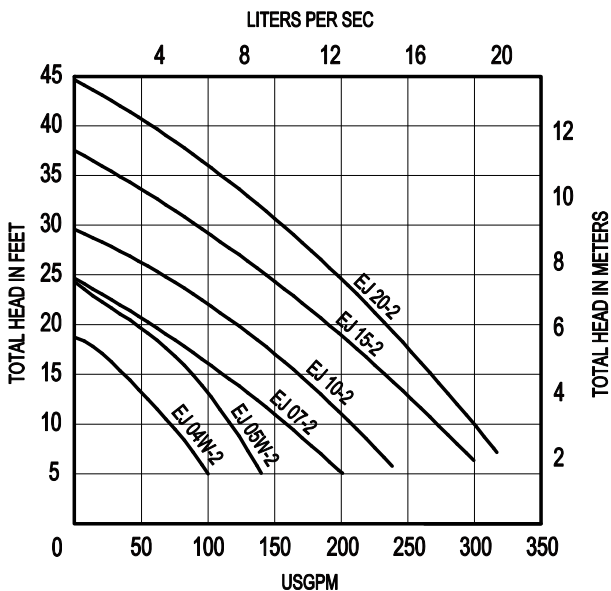

Sewage Ejectors 3 Inch

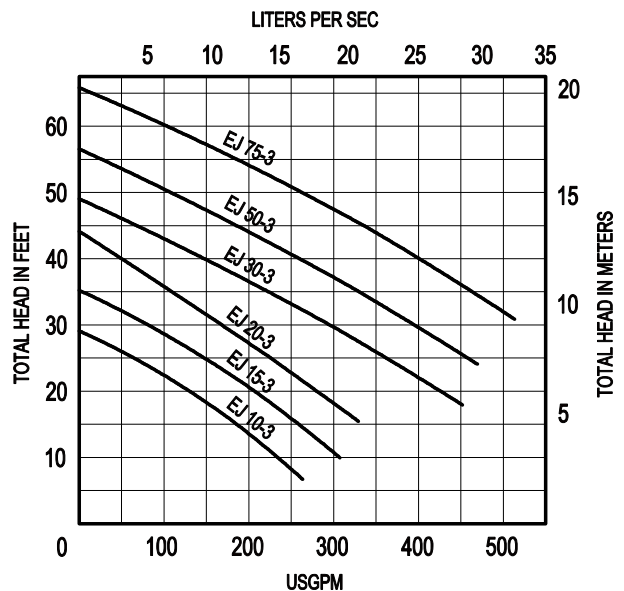

Sewage Ejectors 4 Inch

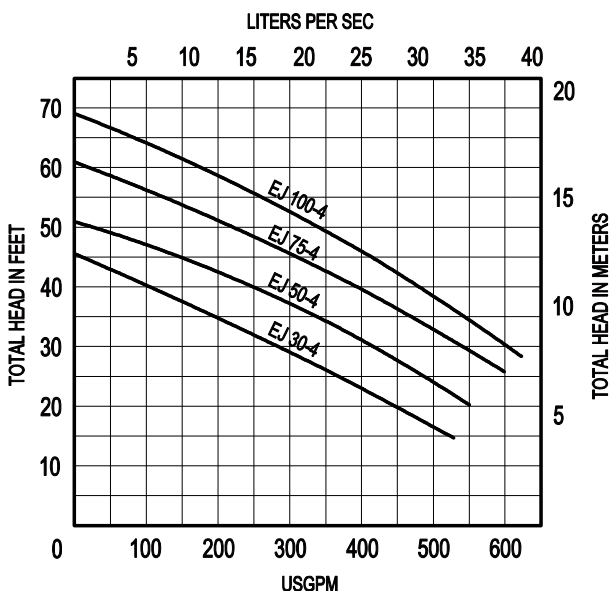

Notes

- Single phase pumps from 0.3 HP through 2 HP have capacitor and thermal protection built in the pump.
- Single phase pumps from 3 HP through 5 HP require an external capacitor start box or control panel, with overload protection.
- All three phase pumps require a control panel with overload protection.

Limitations

- Maximum ambient temperature: +40°C (104°F).
- Maximum submergence depth: 66ft (20m).

ABS SCAVENGER® SUBMERSIBLE EFFLUENT AND SEWAGE EJECTOR PUMPS

Effluent Pumps

Model	HP	Phase	RPM	Voltage	Amps	Discharge	Solids Size	Max Head (feet)	Max Flow (gpm)	Weight (Lbs.)
EF 03W	0.3	1	3450	115	7.2	2"NPT Vertical	3/4"	37	40	21.6
EF 04W	0.4	1	3450	115	9.1	2"NPT Vertical	5/8"	40	80	28.6
EF 05W	0.5	1	3450	115/208-230	13.2/6.6	2"NPT Vertical	5/8"	50	88	35.8
EF 05W-1H	0.5	1	3450	115/208-230	15/7.5	1 1/4" Horiz. NPT	5/8"	73	44	68
EF 10W-1H	1	1	3450	208-230	13	1 1/4" Horiz. NPT	5/8"	108	44	70
EF 10W-2	1	1	3450	208-230	13	2"NPT Vertical	3/4"	73	160	72
EF 10D-2	1	3	3450	208-230/460,575	5.8/2.9,2.3	2"NPT Vertical	3/4"	73	160	57
EF 20D-2	2	3	3450	208-230/460,575	7.6/3.8,3.0	2"NPT Vertical	3/4"	85	175	68

Sewage Pumps

Model	HP	Phase	RPM	Voltage	Amps	Discharge	Solids Size	Max Head (feet)	Max Flow (gpm)	Weight (Lbs.)
EJ 04W	0.4	1	1750	115	6.6	2"NPT Vertical	2"	18	100	31.9
EJ 05W	0.5	1	1750	115/208-230	10.6/4.9	2"NPT Vertical	2"	24	140	35.2
EJ 07W	0.7	1	1750	115/208-230	13.8/6.9	2"Horiz. Flange*	2"	24	200	77
EJ 07D	0.7	3	1750	208-230/460,575	5.0/2.5,2.0	2"Horiz. Flange*	2"	24	200	70
EJ 10W-2	1	1	1750	208-230	10	2"Horiz. Flange*	2"	30	240	77
EJ 10D-2	1	3	1750	208-230/460,575	5.0/2.5,2.0	2"Horiz. Flange*	2"	30	240	70
EJ 15W-2	1.5	1	1750	208-230	15	2"Horiz. Flange*	2"	37	300	90
EJ 15D-2	1.5	3	1750	208-230/460,575	7.0/3.5,2.8	2"Horiz. Flange*	2"	37	300	84
EJ 10W-3	1	1	1750	208-230	10	3"Horiz. Flange	2 1/2"	30	265	77
EJ 10D-3	1	3	1750	208-230/460,575	5.0/2.5,2.0	3"Horiz. Flange	2 1/2"	30	265	70
EJ 15W-3	1.5	1	1750	208-230	15	3"Horiz. Flange	2 1/2"	35	300	90
EJ 15D-3	1.5	3	1750	208-230/460,575	7.0/3.5,2.8	3"Horiz. Flange	2 1/2"	35	300	84
EJ 20W-2	2	1	1750	208-230	19.0	2"Horiz. Flange*	2"	45	320	90
EJ 20D-2	2	3	1750	208-230/460,575	9.0/4.5,3.6	2"Horiz. Flange*	2"	45	320	84
EJ 20W-3	2	1	1750	208-230	19	3"Horiz. Flange	2 1/2"	44	330	90
EJ 20D-3	2	3	1750	208-230/460,575	9.0/4.5,3.6	3"Horiz. Flange	2 1/2"	44	330	84
EJ 30W-3	3	1	1750	208-230	23.0	3"Horiz. Flange	2 1/2"	50	450	147
EJ 30D-3	3	3	1750	208-230/460,575	13.0/6.5,5.2	3"Horiz. Flange	2 1/2"	50	450	143
EJ 30W-4	3	1	1750	208-230	23.0	4"Horiz. Flange	3"	46	525	154
EJ 30D-4	3	3	1750	208-230/460,575	13.0/6.5,5.2	4"Horiz. Flange	3"	46	525	150
EJ 50W-3	5	1	1750	208-230	27.0	3"Horiz. Flange	2 1/2"	57	470	161
EJ 50D-3	5	3	1750	208-230/460,575	19.0/9.5,7.6	3"Horiz. Flange	2 1/2"	57	470	154
EJ 50W-4	5	1	1750	208-230	27.0	4"Horiz. Flange	3"	52	550	165
EJ 50D-4	5	3	1750	208-230/460,575	19.0/9.5,7.6	4"Horiz. Flange	3"	52	550	158
EJ 75D-3	7.5	3	1750	208-230/460,575	23.0/11.5,9.2	3"Horiz. Flange	2 1/2"	67	525	161
EJ 75D-4	7.5	3	1750	208-230/460,575	23.0/11.5,9.2	4"Horiz. Flange	3"	61	600	165
EJ 100D-4	10	3	1750	208-230/460,575	28.0/14.0,11.2	4"Horiz. Flange	3"	70	620	170

*includes elbow to convert to 2" Vertical NPT

Identification Code

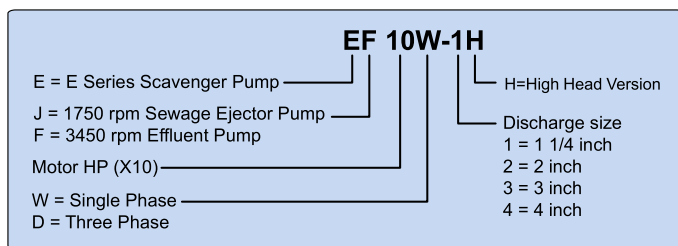

Motor

Submersible single phase and three phase squirrel cage induction motors. Effluent pumps use 2 pole (3450 rpm) motors. Sewage ejector pumps use 4 pole (1750 rpm) motors.

Voltage: 115 and 208-230 V for single phase, 208-230, 460 or 575 V for three phase.

Insulation class B or F depending on the model.

Protection type IP68.

Materials of construction

Motor	Standard
Seal chamber	Cast iron ASTM A-48 Class 35B [GG 25]
Motor housing	Cast iron ASTM A-48 Class 35B [GG 25]
Motor shaft	Stainless steel AISI 420 [1.4021]
Fasteners (medium contact)	Stainless steel AISI 304 [1.4301]
Hydraulics	Standard
Volute	Cast iron ASTM A-48 Class 35B [GG 25]
Impeller	Cast iron ASTM A-48 Class 40 [GG 25], Polybutylene Terephthalate (PBT) with 30% of glass fiber on small pumps [EF 03/04/05 and EJ 04/05]
Bottom plate	Cast iron ASTM A-48 Class 35B [GG 25]
Pedestal	Cast iron ASTM A-48 Class 35B [GG 25]
Fasteners	Stainless steel AISI 304 [1.4301]

Standard and option

Description	Standard	Option
Protection type	IP 68	-
Max. ambient temperature	40°C (104°F)	-
Main voltage	115, 208-230, 460 and 575V	-
Voltage tolerance	+/-10%	-
Insulation class	B or F depending on model	-
Approval	CSA(U)	-
Cables	SE00W, SJE00W, SJTOW	-
Cable length	20'	On request
Mechanical Seal	Double - Carbon/Ceramic	SiC/SiC

The Scavenger Triple Seal System

This ABS exclusive design provides three levels of sealing for outstanding reliability. A double mechanical seal located inside the oil chamber provides two full levels of sealing. An additional V-Ring type lip seal between the oil chamber and pump volute provides a third extra larger level of sealing, and enhanced mechanical seal protection.

**The Scavenger Triple Seal System is only available on scavengers 3/4 hp and above.

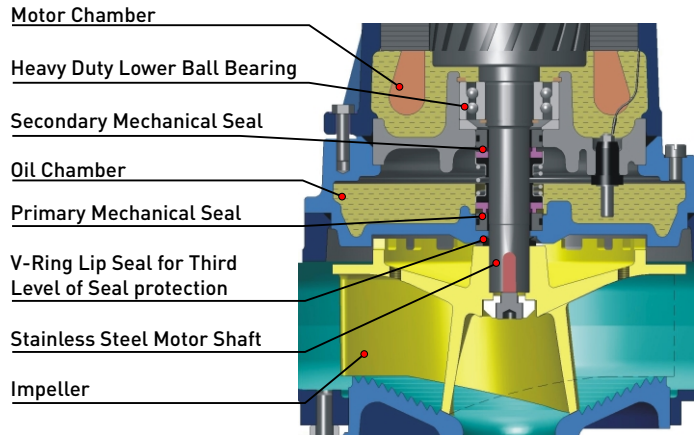

ABS Monitoring System

Scavenger 3HP - 10HP includes the ABS Monitoring System. This system provides normally closed thermal overload switched in the motor winding, and the ABS Seal minder moisture detection probe in the mechanical seal chamber. Wires for the sensors emerge from the pump in a separate control cable. These wires must be connected to the control panel for sensor operation (ABS Seal minder relay required in the panel for moisture detection alarm).

Effluent Pumps 1 1/4 Inch

Transportable Installation

Type	Weight (lb)
EF 05W - 1H	68
EF 10W - 1H	68

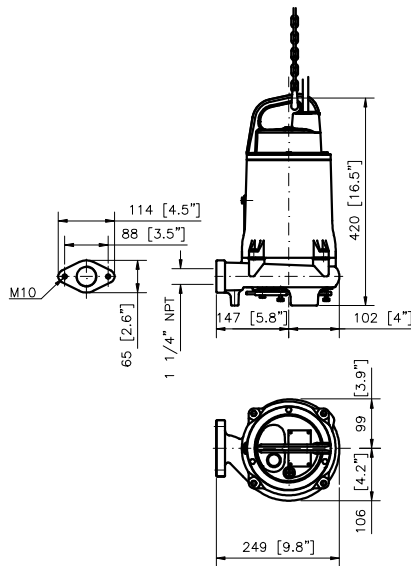

Wet-well Installation

Type	Weight (lb)
EF 05W - 1H	68
EF 10W - 1H	68

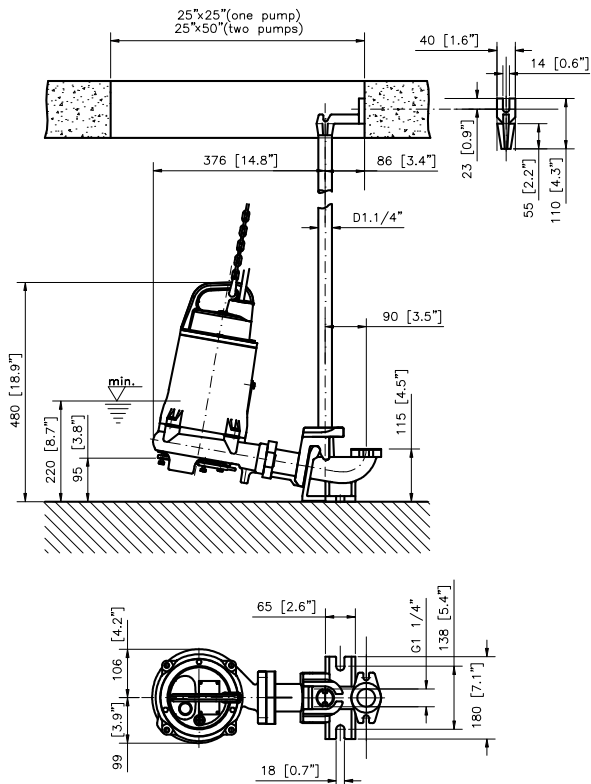

Effluent Pumps 2 Inch

Transportable Installation

Type	Weight (lb)
EF 03W - 2	22

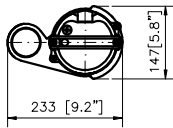
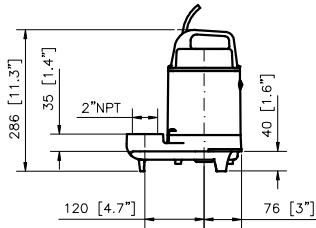

Type	Weight (lb)	H mm (in)
EF 04W - 2	28.6	312 (12.3")
EF 05W - 2	35.8	337 (13.3")

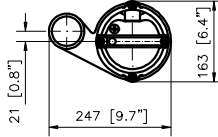
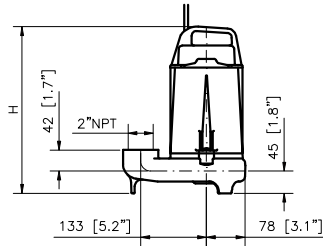

Type	Weight (lb)	H mm (in)
EF 10D - 2	57	401 (15.8")
EF 10W - 2	62	420 (16.5")
EF 10W - 2	68	464 (18.3")

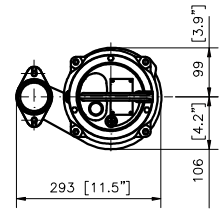
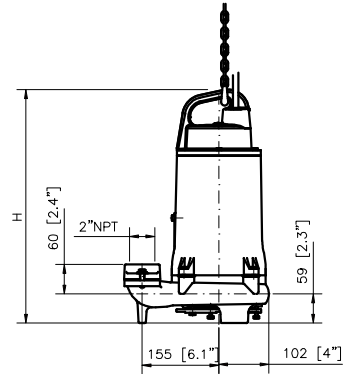

Sewage Ejectors 2 Inch

Transportable Installation

Type	Weight (lb)	H mm (in)	B mm (in)	C mm (in)	D mm (in)
EJ 04W - 2	31.9	377 (14.9")	170 (6.7")	251 (9.9")	80 (3.15")
EJ 05W - 2	35.2	402 (15.8")	187 (7.4")	263 (10.4")	94 (3.70")

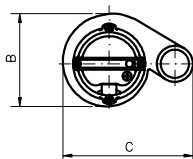
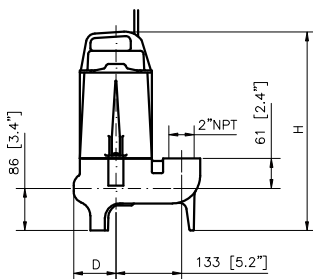

Type	Weight (lb)	H mm (in)
EJ 07W - 2	77	487 (19.3")
EJ 10W - 2	77	487 (19.3")
EJ 15W - 2	90	532 (21")
EJ 20W - 2	90	532 (21")
EJ 07D - 2	70.4	468 (18.4")
EJ 10D - 2	70.4	468 (18.4")
EJ 15D - 2	83.6	513 (20.2")
EJ 20D - 2	83.6	513 (20.2")

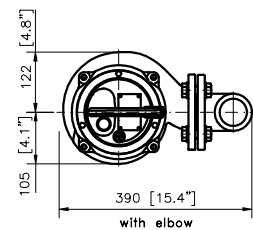
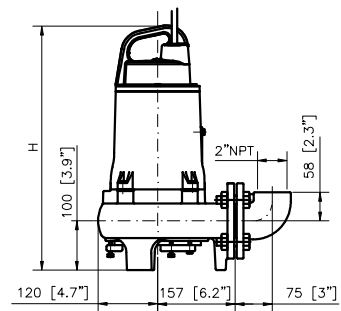

Sewage Ejectors 2x3 Inch

Transportable Installation

Type	Weight (lb)	H mm (in)
EJ 07W - 2	77	487 (19.2")
EJ 10W - 2	77	487 (19.2")
EJ 15W - 2	90	532 (21")
EJ 20W - 2	90	532 (21")
EJ 07D - 2	70.4	468 (18.4")
EJ 10D - 2	70.4	468 (18.4")
EJ 15D - 2	83.6	513 (20.2")
EJ 20D - 2	83.6	513 (20.2")

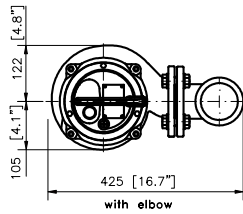
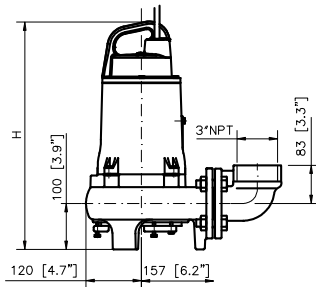

Wet-well Installation

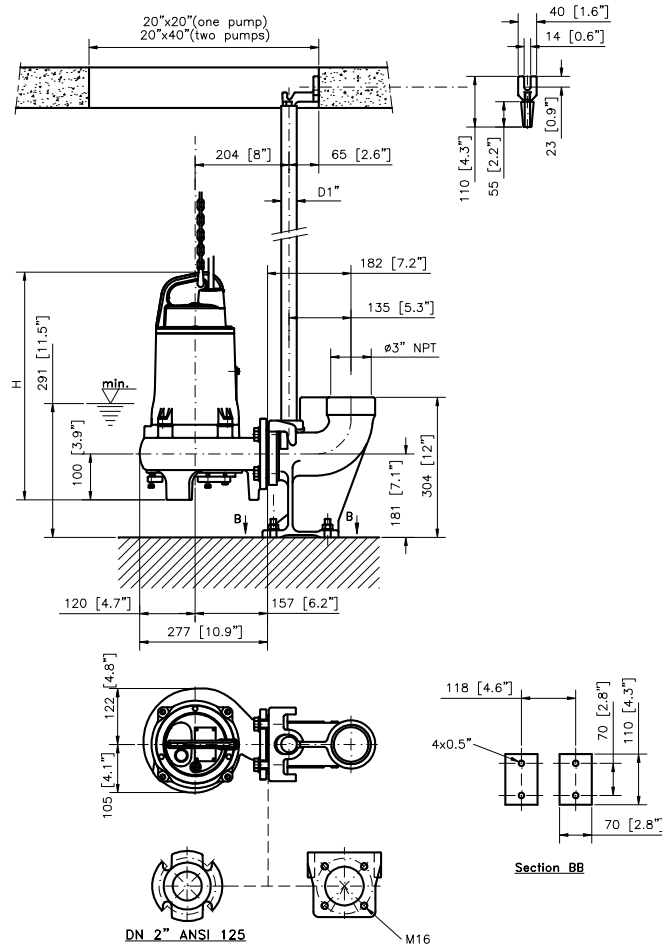

Sewage Ejectors 3 Inch

Transportable Installation

Type	Weight (lb)	H mm (in)
EJ 10W - 3	77	509 (20")
EJ 15W - 3	90.2	553 (21.8")
EJ 20W - 3	90.2	553 (21.8")
EJ 10D - 3	70.4	485 (19")
EJ 15D - 3	83.6	534 (21")
EJ 20D - 3	83.6	534 (21")

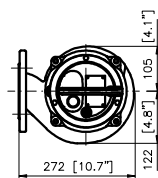
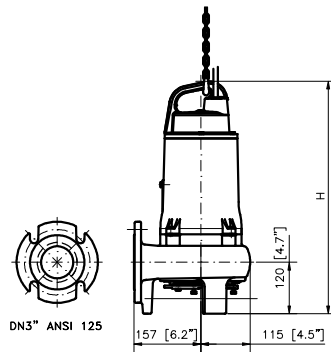

Wet-well Installation

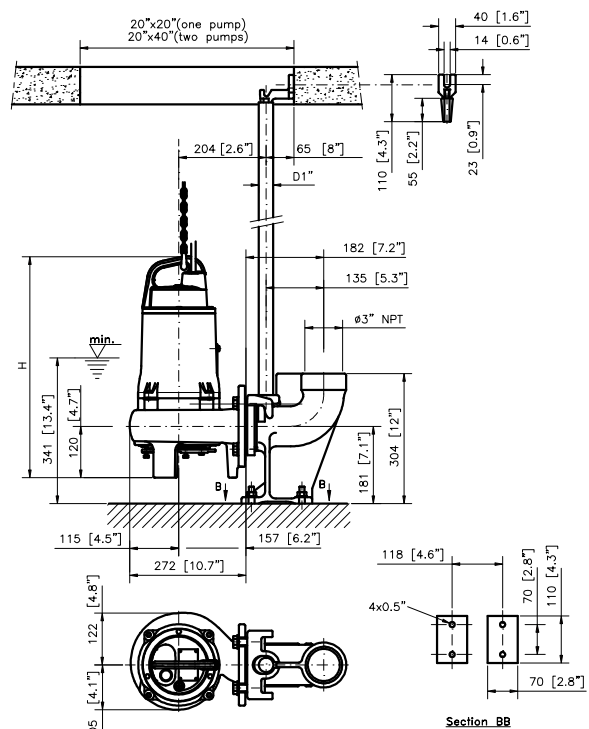

Sewage Ejectors 3 Inch

Transportable Installation

Type	Weight (lb)	H mm (in)
EJ 30W - 3	147.4	685 (27")
EJ 50W - 3	160.6	685 (27")
EJ 30D - 3	154	665 (26.2")
EJ 50D - 3	160.6	685 (27")
EJ 75D - 3	138.6	685 (27")

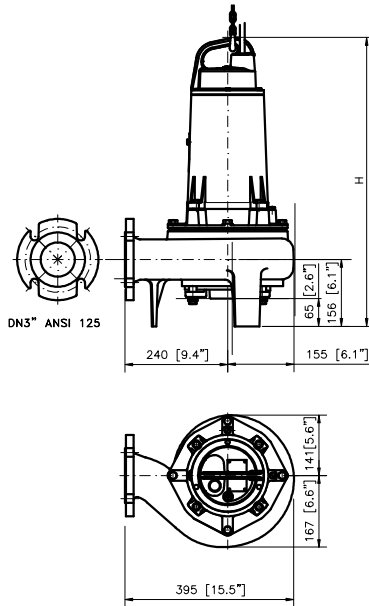

Wet-well Installation

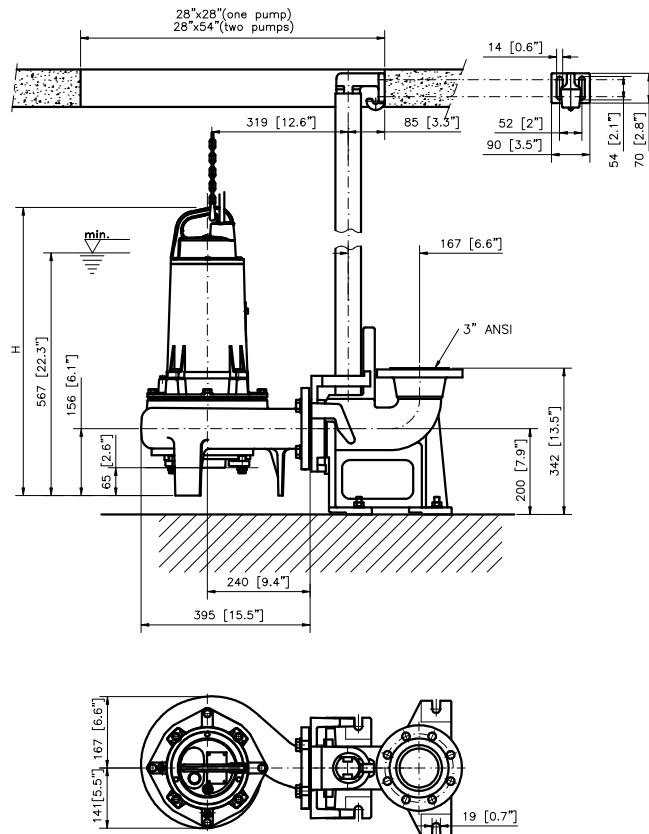

Sewage Ejectors 4 Inch

Transportable Installation

Type	Weight (lb)	H mm (in)
EJ 30W - 4	154	685 (27")
EJ 50W - 4	165	685 (27")
EJ 30D - 4	149.6	665 (26.2")
EJ 50D - 4	158.4	685 (27")
EJ 75D - 4	165	685 (27")
EJ 100D - 4	165	685 (27")

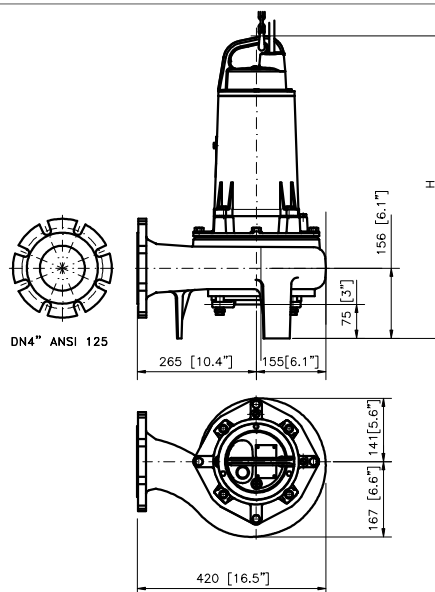

Wet-well Installation

Type	Weight (lb)	H mm (in)
EJ 30W - 4	154	685 (27")
EJ 50W - 4	165	685 (27")
EJ 30D - 4	149.6	685 (27")
EJ 50D - 4	158.4	685 (27")
EJ 75D - 4	165	685 (27")
EJ 100D - 4	165	685 (27")

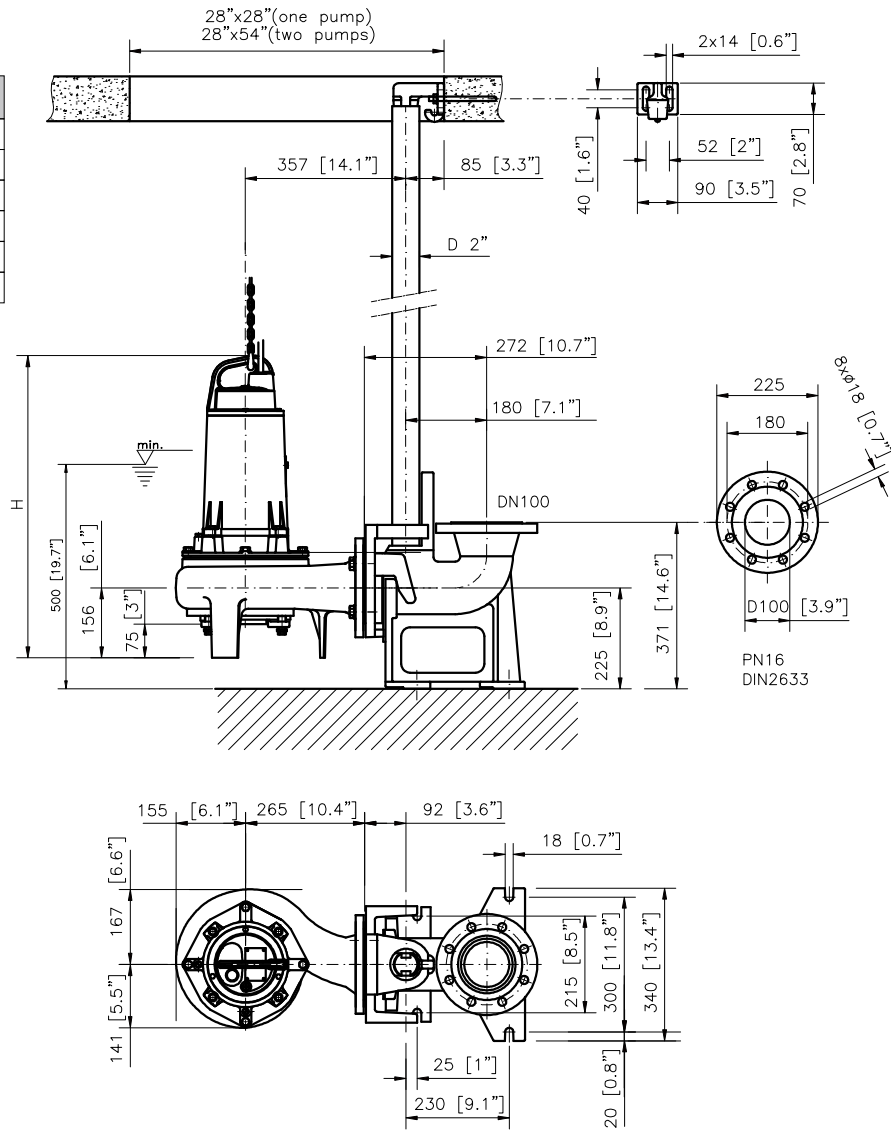

Corporate office:
 ABS USA
 140 Pond View Drive
 Meriden, CT 06450
 Tel (203) 238-2700
 Fax (203) 238-0738

Regional offices:
 Southeast Region
 111 Maritime Drive
 Sanford, FL 32771
 Tel (407) 330-3456
 Fax (407) 330-3404

ABS Canada
 1401 Meyerside Drive, Unit #2
 Mississauga, Ontario L5T 1 G8
 Tel (905) 670-4677
 Fax (905) 670-3709